

# Smart Parking

## Technical Guide

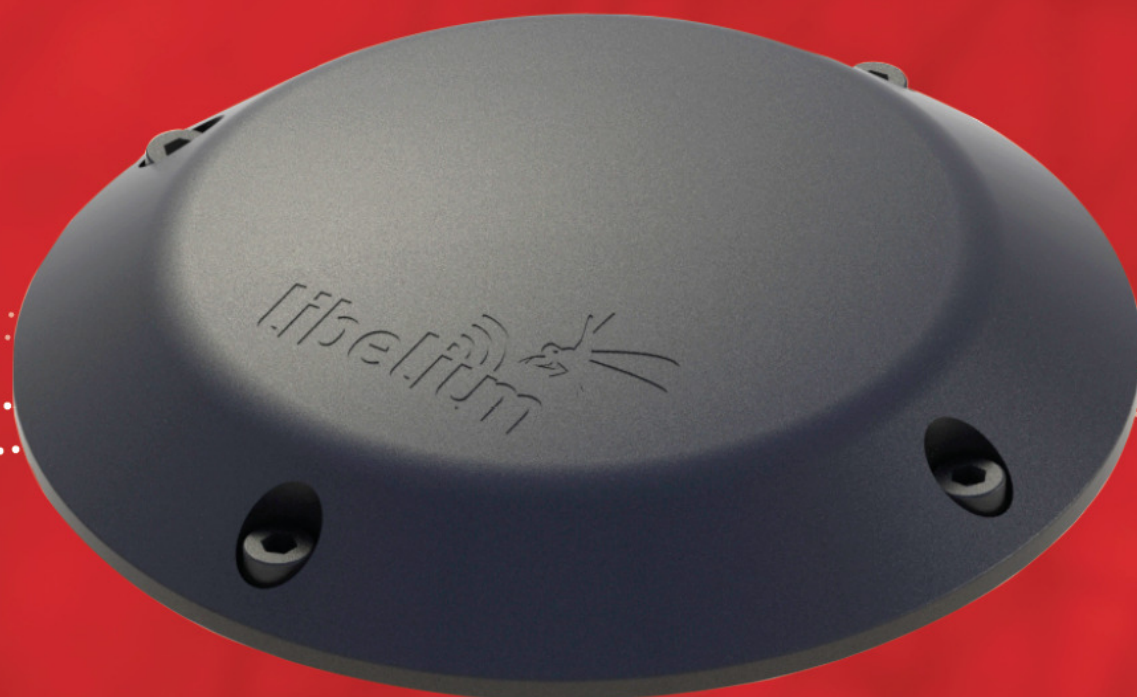

Document version: v7.2 - June 21, 2019  
© Libelium Comunicaciones Distribuidas S.L.

# INDEX

<b>1. Introduction</b> .....	<b>5</b>
<b>2. Network architecture</b> .....	<b>6</b>
2.1. Smart Parking node .....	7
2.2. LoRaWAN base station .....	7
2.3. LoRaWAN Network Server .....	7
2.4. Libelium Cloud and Customer Server .....	8
<b>3. Smart Parking node</b> .....	<b>10</b>
3.1. Hardware description.....	10
3.1.1. Node versions .....	11
3.1.2. LoRaWAN regions.....	11
3.1.3. LoRaWAN protocol and parameters .....	12
3.2. Power and time consumption .....	12
3.2.1. Smart Parking EU .....	12
3.2.2. Smart Parking US .....	13
3.3. User switches .....	13
3.4. Reset button .....	14
3.5. Node setup .....	14
3.5.1. "Ready to install" state .....	14
3.5.2. How to close the Smart Parking node.....	15
3.5.3. "Magnet start-up" process .....	16
3.6. How the node works .....	17
3.6.1. Frame types .....	17
3.6.2. Frame header.....	18
3.6.3. Frame payload .....	18
3.6.4. Node program flowchart .....	20
3.7. Node parameters .....	21
3.7.1. Parameters description and ranges .....	21
3.7.2. Understanding Info and Keep-alive frames .....	22
3.7.3. Understanding night-mode.....	22
3.7.4. Understanding RTC synchronization .....	23
3.7.5. Understanding uplink frames format (real example) .....	24
3.7.6. Factory default values .....	26
3.7.7. Configure new parameter values.....	26
<b>4. Libelium Cloud management</b> .....	<b>28</b>
4.1. Introduction to the Libelium SCM .....	28
4.2. SCM account .....	29
4.2.1. Creating an account.....	29

4.2.2.	Signing in .....	30
4.3.	Smart Parking nodes registration .....	31
4.4.	Editing Smart Parking nodes .....	32
4.5.	Export CSV file with nodes credentials .....	33
<b>5.</b>	<b>Smart Devices App .....</b>	<b>34</b>
5.1.	How to install the Smart Devices App .....	34
5.1.1.	Start Smart Devices App on Windows .....	35
5.1.2.	Start Smart Devices App on GNU/Linux .....	36
5.1.3.	Start Smart Devices App on MacOSX .....	36
5.2.	Upgrading the Smart Devices App .....	36
5.3.	Smart Parking v2 .....	36
5.3.1.	How to plug the Smart Parking node .....	37
5.3.2.	Configuration .....	37
5.3.3.	Programmer (change node parameters) .....	38
5.3.4.	Firmware upgrade .....	39
5.3.5.	Factory Reset .....	40
<b>6.</b>	<b>LoRaWAN Network Server setup .....</b>	<b>42</b>
6.1.	Loriot .....	42
6.1.1.	Log in .....	42
6.1.2.	Create a new Loriot application .....	43
6.1.3.	Manage Loriot output data .....	44
6.1.4.	How to delete unused Loriot applications .....	45
6.1.5.	How to create a single device manually .....	45
6.1.6.	Nodes batch provisioning in Loriot .....	46
6.2.	Actility .....	48
6.2.1.	How to create a new Application Server .....	48
6.2.2.	How to create a new AS routing profile .....	50
6.2.3.	How to create new devices manually .....	52
6.2.4.	Nodes batch provisioning in Actility .....	53
<b>7.</b>	<b>Customer Server .....</b>	<b>56</b>
7.1.	Installation .....	57
7.1.1.	Docker .....	57
7.1.2.	Server .....	57
7.2.	Deploying .....	57
7.2.1.	Docker .....	57
7.2.2.	Server .....	58
7.3.	Configuring the application .....	59
7.3.1.	How to configure Loriot .....	59
7.3.2.	How to configure Actility .....	61
7.4.	Making the server accessible from anywhere .....	61
7.4.1.	Mandatory for Loriot and Actility platforms .....	61
7.5.	Remote Configuration Form .....	61

---

7.6.	Customer Server Core .....	64
7.6.1.	End-point .....	64
7.6.2.	Data Parser .....	64
7.6.3.	Database .....	65
7.7.	Modifying the Customer Server .....	67
7.7.1.	Modifying the Database .....	67
7.7.2.	Adding a new unsupported LoRaWAN Network Server .....	67
<b>8.</b>	<b>Libelium Smart Parking Cloud Service .....</b>	<b>69</b>
8.1.	Smart Parking Cloud Service .....	69
8.1.1.	Remote Configuration .....	70
8.1.2.	Service Configuration .....	72
8.1.3.	Log .....	73
8.1.4.	Tools .....	74
<b>9.</b>	<b>Deployment and installation .....</b>	<b>77</b>
9.1.	Step-by-step guideline .....	77
9.2.	How to place the nodes .....	78
9.3.	Node installation .....	79
9.3.1.	Triple installation option .....	79
9.3.2.	On-surface node installation .....	80
9.3.3.	Underground node installation .....	85
9.3.4.	Semi-underground node installation .....	88
9.4.	Node start-up .....	89
9.5.	Working example .....	90
<b>10.</b>	<b>Certifications .....</b>	<b>91</b>
10.1.	CE (European Union) .....	91
10.2.	FCC (United States) .....	91
<b>11.</b>	<b>Safety Guides .....</b>	<b>92</b>
11.1.	Smart Parking Chemical Fixing Cartridge .....	92
<b>12.</b>	<b>Documentation changelog .....</b>	<b>104</b>



# 1. Introduction

The Smart Parking v2 solution developed by Libelium allows citizens to detect available parking slots.

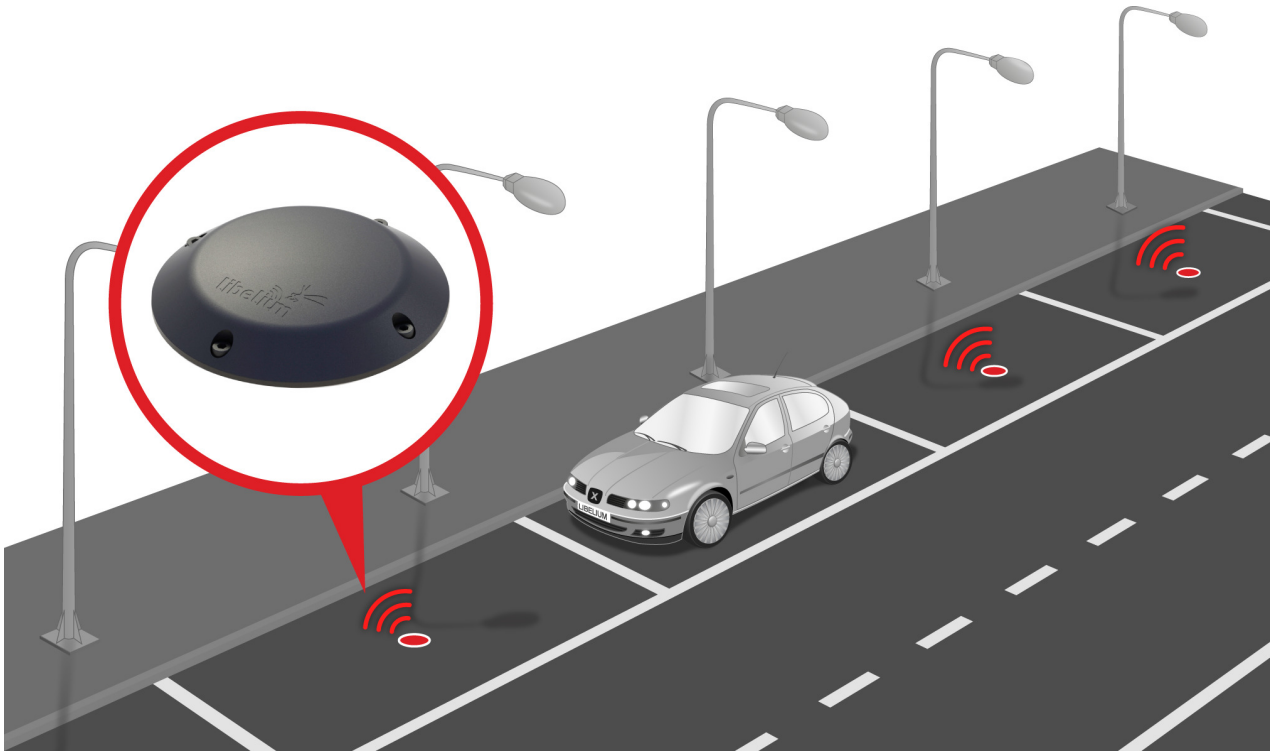

Figure : Smart Parking node developed by Libelium

The node applies intelligent algorithms to detect changes in the state of the parking slot. Then data is transmitted with the LoRaWAN radio to the final server.

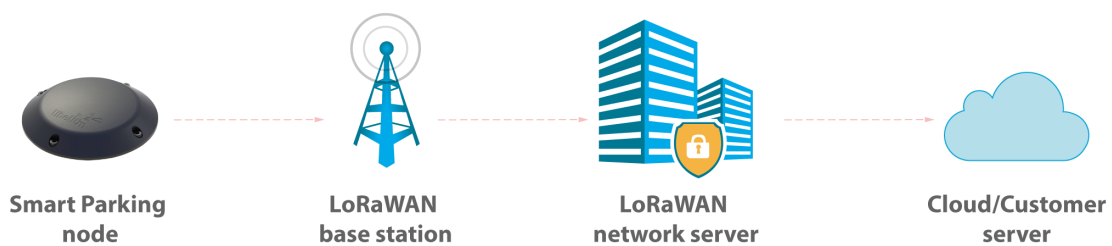

Figure : Simplified Smart Parking network architecture

The nodes provisioning has been enormously improved. The nodes are delivered with default time settings and also unique LoRaWAN identifiers and keys. So it is easy to use the default settings to register all nodes in the LoRaWAN network server at a time.

The Smart Parking node improves the detection and stability performance thanks to a radar sensor which permits to certainly know when objects are placed over the device. The next table shows a comparative analysis of the current sensor technologies in the Smart Parking market:

	Radar	Infra-red	Magnetometer
Reliability against nearby vehicle movement	✓	✓	✗
Reliability against nearby parked vehicles	✓	✓	✗
Reliability against electromagnetic interferences	✓	✓	✗
Reliability in any lighting scenario	✓	✗	✓
Stability during long-duration vehicle stays	✓	✓	✗
Do not need an aperture in enclosure	✓	✗	✓
Immunity against dirt or dust on enclosure	✓	✗	✓

The node provides OTA-S (Over-The-Air Setup). This allows the user to remotely configure the node parameters (sleep time, keep-alive, night-mode, etc) via the Remote Configuration Form. That makes it possible to directly install the nodes with factory default settings and then update them from the server side.

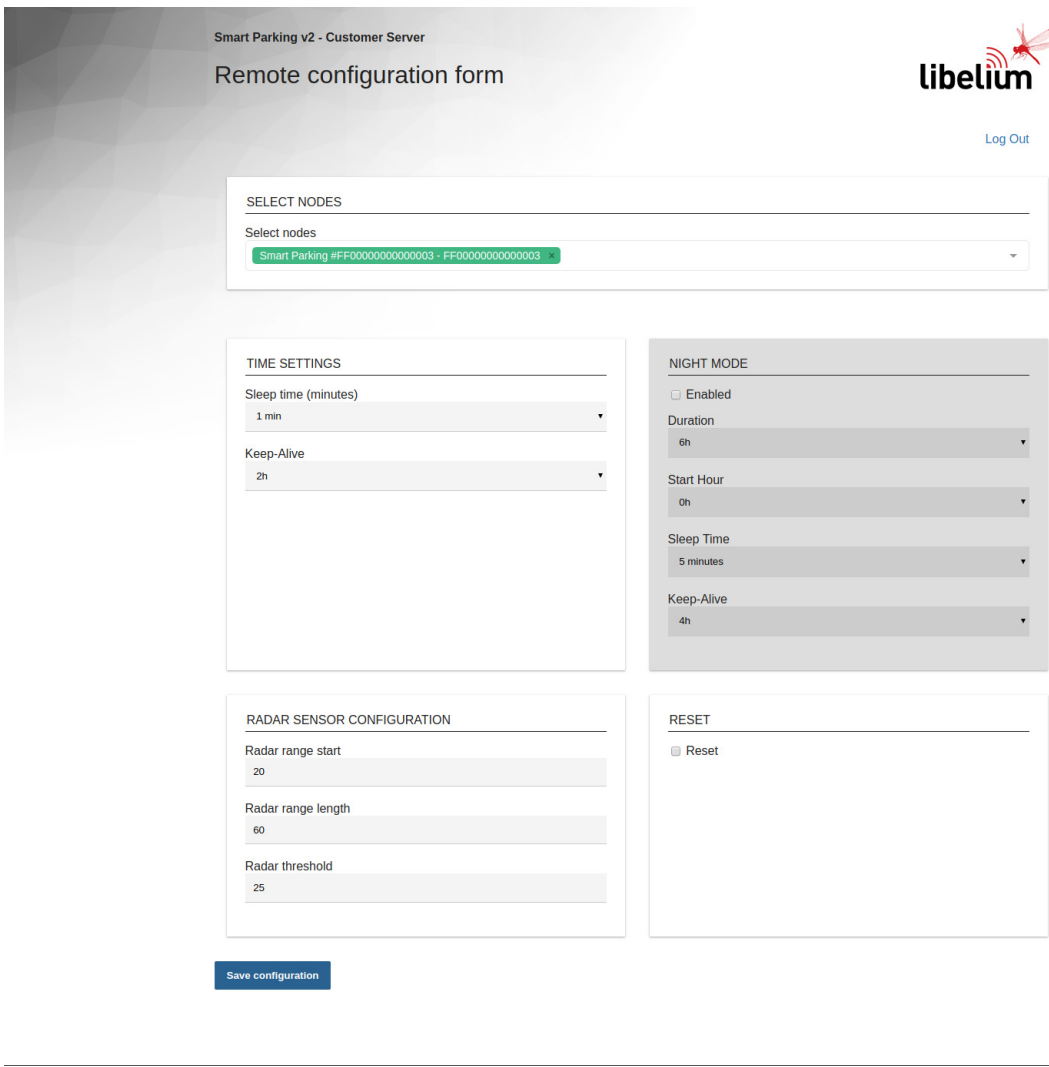

Smart Parking v2 - Customer Server

Remote configuration form

libelium 

[Log Out](#)

**SELECT NODES**

Select nodes

Smart Parking #FF00000000000003 - FF00000000000003

**TIME SETTINGS**

Sleep time (minutes)

1 min

Keep-Alive

2h

**NIGHT MODE**

Enabled

Duration

6h

Start Hour

0h

Sleep Time

5 minutes

Keep-Alive

4h

**RADAR SENSOR CONFIGURATION**

Radar range start

20

Radar range length

60

Radar threshold

25

**RESET**

Reset

[Save configuration](#)

© Libelium Comunicaciones Distribuidas

Figure : Remote Configuration Form

## 2. Network architecture

The network architecture of Smart Parking is based on the next elements:

- Smart Parking node
- LoRaWAN base station
- LoRaWAN Network Server
- Libelium Cloud or Customer Server

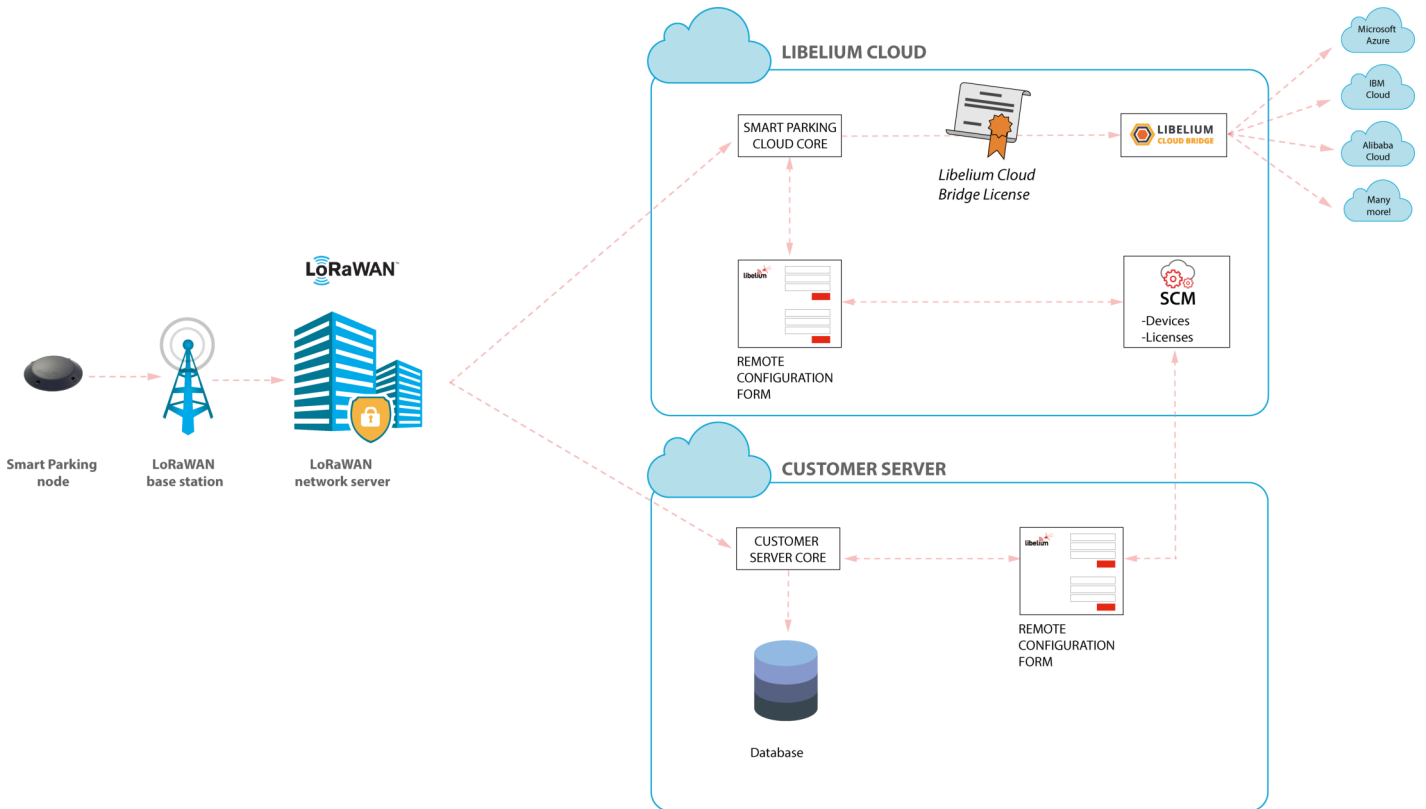

Figure : Smart Parking network architecture

## 2.1. Smart Parking node

The Smart Parking node is the device installed in each parking slot. When the device detects a change of the parking slot status (free/occupied), it sends a frame to the LoRaWAN base station.



Figure : Smart Parking node

## 2.2. LoRaWAN base station

The LoRaWAN base station (also known as gateway) must be installed in the surrounding area next to the parking nodes. It receives data and forwards it to the LoRaWAN Network Server.

Libelium distributes base stations for LoRaWAN networks. All of them have LoRaWAN connection; some feature Ethernet, WiFi or 4G connectivity too. Some base stations are ready to work outdoors (IP67 grade). Some of them come pre-configured for certain LoRaWAN network servers (see next section). Also, some of them integrate an embedded LoRaWAN Network Server.



Figure : LoRaWAN base station

## 2.3. LoRaWAN Network Server

The nodes registration must be done in the Network Server in order to receive LoRaWAN data from all nodes in the network. Each node must be registered with an identifier and some encryption keys so the Network Server can receive and decrypt the packets successfully.

The LoRaWAN Network Server purpose is to translate data from the LoRaWAN wireless network to an IP network. Therefore, when Smart Parking nodes packets are received, a callback is performed in order to send data to the

Libelium Cloud or to the Customer Server.

## 2.4. Libelium Cloud and Customer Server

The LoRaWAN Network Server connects to the final server, which can be the Libelium Cloud or the Customer Server.

The LoRaWAN network servers currently supported are:

- Lorient
- Actility

If the customer wants to use a new LoRaWAN Network Server, then the Data Parser block must be modified in order to receive data properly. Keep in mind that each Network Server implements their own HTTPS callback using a different format.

The Remote Configuration Form allows the user to update the settings of each node (sleep time, keep-alive time, night-mode, etc). The update is done remotely via LoRaWAN downlink radio packets.

The difference between the 2 types of server differ in the the possible client needs:

- The Customer Server is a software system provided by Libelium which permits to receive, decode and insert data into a standard MySQL database. It is mandatory that the user sets up her own server to host the Customer Server. See "[Customer Server](#)" chapter for further information.
- The Libelium Cloud is a service provided by Libelium which permits to receive, decode and redirect the data to the final 3rd party IoT cloud (Amazon, Azure, etc). This retransmission is done thanks to the cloud connectors running on the Libelium Cloud Bridge.

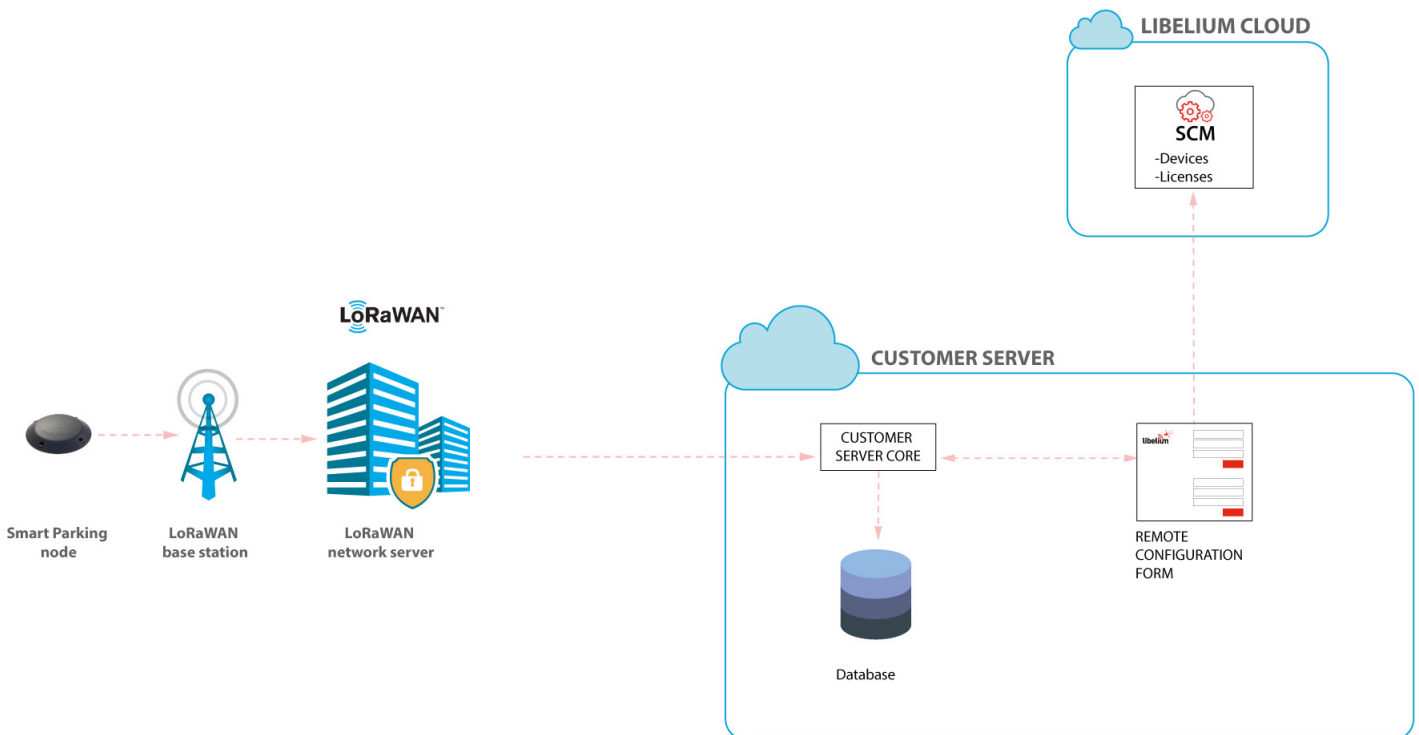

Figure : Customer Server scenario

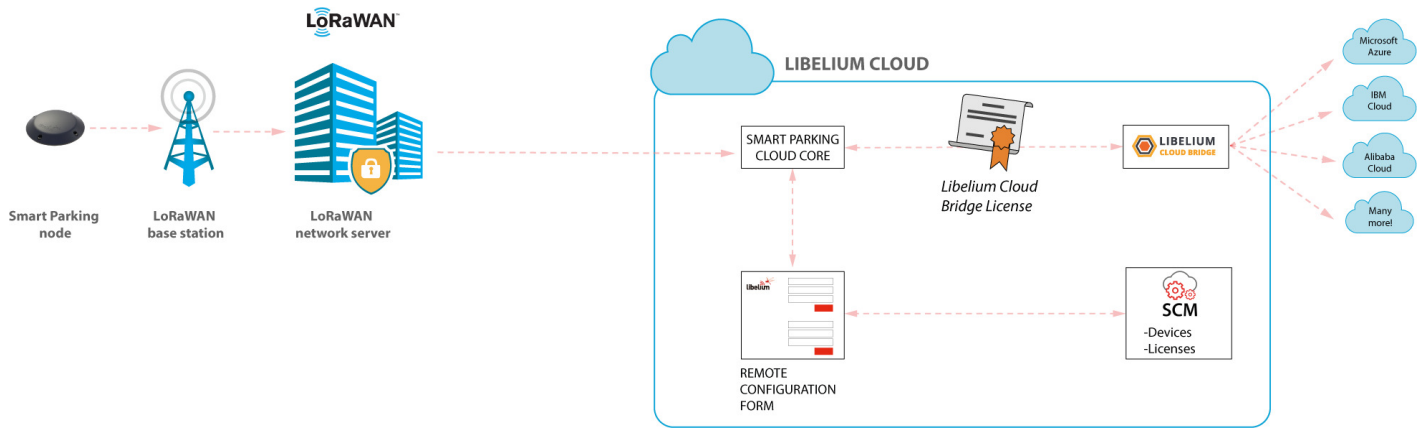

Figure : Libelium Cloud service scenario



## 3. Smart Parking node

### 3.1. Hardware description

The Smart Parking node is based on 2 different pieces: the base and the external enclosure. The base of the Smart Parking node includes the PCB, the battery, the antenna and the internal enclosure piece.



*Figure : Base of a Smart Parking node*

The base is screwed to the external enclosure piece:

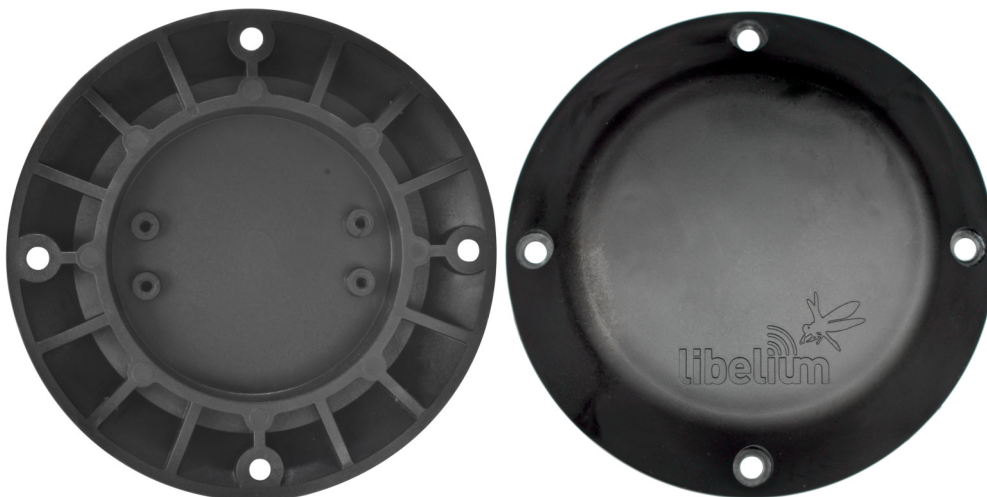

*Figure : External enclosure*

The next table shows the basic Smart Parking node characteristics.

<b>Power supply</b>	Built-in lithium-thionyl chloride (Li-SOCl <sub>2</sub> ) batteries; expected lifetime of 4-10 years*
<b>Configurable sleep time</b>	Min: 20 s / max: 10 min
<b>Radio protocol</b>	LoRaWAN module
<b>Dual detection</b>	Radar (main) and magnetic (backup)
<b>Provisioning</b>	Ready to install (default LoRaWAN OTAA IDs and key are loaded to each node)
<b>Node configuration</b>	Via "Remote Configuration Form" (web form)
<b>LoRaWAN configuration</b>	Via "Smart Devices App" (Java desktop application)
<b>Operating temperature</b>	-20 to +65 °C

(\*) Under normal circumstances and depending on settings

### 3.1.1. Node versions

Libelium provides the next versions of Smart Parking:

Reference	Version	Operating frequency
SP-EU	Smart Parking EU	863.0 to 870.0 MHz (LoRaWAN EU863-870)
SP-US	Smart Parking US	902.0 to 928.0 MHz (LoRaWAN US902-928)
SP-APLA-AU	Smart Parking APAC / LATAM / AU / AU915	915.2 to 927.8 MHz (LoRaWAN AU915-928)
SP-IN	Smart Parking IN	865.0 to 867.0 MHz (LoRaWAN IN865-867)
SP-APLA-AS	Smart Parking APAC / LATAM / AU / AS923	923 MHz (LoRaWAN AS923)

### 3.1.2. LoRaWAN regions

The Smart Parking node supports the next LoRaWAN regions:

LoRaWAN region	Supported by
EU 863-870 MHz ISM Band (Europe)	Smart Parking EU
US 902-928 MHz ISM Band (United States)	Smart Parking US
AU 915-928 MHz ISM Band (Australia)	Smart Parking APAC / LATAM / AU / AU915
IN 865-867 MHz ISM Band (India)	Smart Parking IN
AS 923 MHz ISM Band (Asia and ASEAN region)	Smart Parking APAC / LATAM / AU / AS923
CN 779-787 MHz ISM Band (China)	Not available
CN 470-510 MHz ISM Band (China)	Not available
KR 920-923 MHz ISM Band (South Korea)	Not available
433 MHz ISM Band (Worldwide)	Not available

If you are interested in further information about LoRaWAN country regulations, please refer to the LoRa Alliance [regional parameters document](#).

### 3.1.3. LoRaWAN protocol and parameters

LoRaWAN is a Low Power Wide Area Network (LPWAN) protocol. It is a spread-spectrum modulation technique at extremely low data-rates which permits sending data achieving long ranges.

The most important LoRaWAN parameters are:

- LoRaWAN EUI: Read-only, 8-byte, unique identifier which defines each LoRaWAN module in the market.
- Device EUI: Read/write, 8-byte identifier configured into the LoRaWAN module to be used as operating identifier. By default, the "LoRaWAN EUI" of the module is factory-configured as "Device EUI" in the Smart Parking node.
- Join mode: ABP or OTAA. Defines how the module joins the network. Different keys are needed for each method.
- Device address: Needed for ABP. The 4-byte address of the the LoRaWAN module. Must be unique in its own sub-network.
- Network Session Key: Needed for ABP. The 16-byte AES key. Used to generate Message Integrity Check.
- Application Session Key: Needed for ABP. The 16-byte AES key. Used to encrypt data.
- Application EUI: Needed for OTAA. The 8-byte application identifier. Needed for opening an OTAA session and exchange encryption keys.
- Application Key: Needed for OTAA. The 16-byte key. Needed for opening an OTAA session and exchange encryption keys.
- Data-rate: Defines the transmission rate (bits per second). Each data-rate settings combines different Spreading Factor (SF) and bandwidth (BW). By default, all LoRaWAN regions use the same data-rate (DR 0). However, depending on the region, that means different SF and BW:
  - LoRaWAN EU863-870 version: SF12 / 125 kHz
  - LoRaWAN IN865-867 version: SF12 / 125 kHz
  - LoRaWAN AS923 version: SF12 / 125 kHz
  - LoRaWAN US902-928 version: SF10 / 125 kHz
  - LoRaWAN AU915-928 version: SF10 / 125 kHz
- ADR: Adaptive Data Rate setting which can be enabled or disabled. If ADR is enabled, the server will optimize the data-rate based on the information collected from the network: the RSSI / SNR of the last received packets.

If you are interested in further information about LoRaWAN specifications, please refer to the [LoRa Alliance specifications document](#).

## 3.2. Power and time consumption

The Smart Parking node firmware executes different steps since the node is started. Firstly, the node's setup and then an infinite loop where every cycle is based on measuring, sending if needed and sleeping. The next tables show the power and time consumption of each step modelled as a pulse of a specific time duration and average power consumption.

### 3.2.1. Smart Parking EU

	Power consumption	Time consumption
<b>Node setup</b>	22.9 mA	59 s
<b>Measure cycle</b>	26 mA	340 ms
<b>Measure and send cycle</b>	17 mA	6 s
<b>Sleep cycle</b>	5.5 uA	Depends on sleep time settings

(\*) LoRaWAN EU is set to the default SF12 settings (worst case). The send process may be lower power if the node is close to the base station.

### 3.2.2. Smart Parking US

	Power consumption	Time consumption
Node setup	21.8 mA	53 s
Measure cycle	26 mA	340 ms
Measure and send cycle	20 mA	3.6 s
Sleep cycle	5.5 uA	Depends on sleep time settings

(\*) LoRaWAN US is set to the default SF10 settings (worst case). The send process may be lower power if the node is close to the base station.

### 3.3. User switches

The Smart Parking node has 2 switches to manage the working mode:

- On/Off switch: Determines whether the node is powered-on or powered-off
- App/Boot switch: When the node is powered-on, this switch determines the performance state of the device
  - App position must be used for a normal operation mode, so the device executes the firmware within it
  - Boot position must be used for configuring purposes only



Figure : Smart Parking node "user switches"

When the node is powered-on (On switch), you can change from App to Boot or viceversa by changing the state of the App/Boot switch. However, you must press the reset button to apply the operation mode change. Another possibility to successfully change the operation mode step-by-step would be to: power down the device (Off switch), change the App/Boot switch, press the reset button and then power on the device.

**Important:**

Never leave the device set to On and Boot for more time than needed. The bootloader does not provide any sleep mode and it will waste the battery of the device. So when you finish reconfiguring the device, please set the node in off state.

## 3.4. Reset button

The reset button can be used to re-start the node in the corresponding operation mode (App or Boot). If the node is set up to "App" (normal operation mode), pressing the reset button will re-start the program execution. On the other hand, if the node is set up to Boot (configuration mode), pressing the reset button will re-start the MCU bootloader for reconfiguration or firmware update.



Figure : Reset button

## 3.5. Node setup

### 3.5.1. "Ready to install" state

**Important:**

*Libelium provides the nodes "ready to install" so the user only needs to install the nodes and follow the "Magnet start-up" process.*

The Smart Parking node has a power-on process in order to put the device into a "ready-to-install" state:

- Step 1: The switches are set to "App" and "Off" (press the reset button to make sure you discharge capacitors)
- Step 2: You power the device on by sliding the switch from "Off" to "On"
- Step 3: Both LEDs (red and green) blink rapidly for 5 times
- Step 4: Red LED blinks once for 1 second to indicate that the device enters sleep mode for the 1st time. Now the node is in a "ready to install" state. The customer should install the node on the real scenario and perform the "Magnet start-up" process.



Figure : The red LED blinks once to indicate ready-to-install state

You can see how the previous steps are performed in this video: [Ready to install process](#)

### 3.5.2. How to close the Smart Parking node

After following the previous steps, the device can be closed. In order to close the node correctly and ensure correct sealing, the following steps must be strictly followed.

- Step 1: Make sure that the screws have the o-rings to prevent water ingress.



Figure : Screws with o-ring

- Step 2: Ensure that the top surface of the gasket is clean and contains no foreign objects.
- Step 3: Place the inner casing inside the outer casing and make sure that the 2 position marks match.

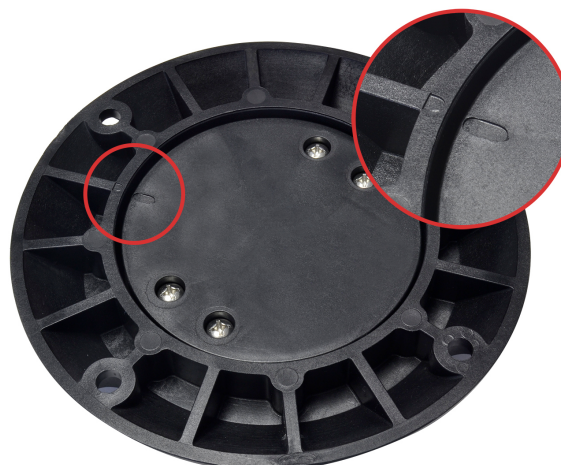

Figure : Enclosure position marks



- Step 4: Insert the screws and tighten them halfway.



*Figure : Screws in their position*

- Step 5: Finally, tighten the 4 screws firmly. Do not use the maximum pressure (do not go all the way with the screws), because the o-rings could be ejected from the screws, and then the waterproof feature would NOT be valid. Besides, do not screw too hard and keep on screwing, because the screws could carve the female sockets, expanding their inner diameter; this would cancel the waterproof quality too.

Libelium manufactures and provides all nodes configured after following all explained steps, so the node is "ready to install". By factory default, all nodes are configured with their unique LoRaWAN EUI and random private keys. On the other hand, if different LoRaWAN parameters are desired, "[Smart Devices App](#)" must be used to change the settings and repeat the previously explained steps.

### 3.5.3. "Magnet start-up" process

Once the node has been set to "ready to install" state and it has been closed and placed on the parking slot, the "magnet start-up" must be done. This process consists on resetting the device using the magnet for 3 consecutive times. Each magnet reset must be separated by at least one second period.

The best way to proceed with the magnet is to go over the enclosure from left to right in a one-motion movement. Then wait for at least one second (although you can wait more) and proceed again until you complete 3 magnet resets.



*Figure : Magnet reset*

In the next video-clip you can see how the "magnet start-up" is performed: [Magnet start-up](#)

After finishing the "magnet start-up", the node starts working normally for the rest of the time. No more three-time "magnet resets" are needed in order to reset the device properly. So if a 4th magnet reset or software reset is applied, the device will reset and continue working normally again.

**Important:**

*The "magnet start-up" is only mandatory when the node is powered from a power-off state. In other words, when the device is set to a "ready to install" state.*

## 3.6. How the node works

### 3.6.1. Frame types

The Smart Parking architecture manages different uplink and downlink frames.

The next table shows the Uplink frames:

Frame type	#num	Description
Start frame 1	4	First frame sent by the node when starting (with params settings)
Start frame 2	5	Second frame sent by the node when starting (with params settings)
Info frame	0	Used to inform a Parking Status change
Keep-alive frame	1	Used to inform the device keeps working since last reported status
Configuration uplink	2	Used to confirm a "Configuration downlink" was applied or not
RTC update request	7	Used to request for an RTC sync once every day

The next table shows the Downlink frames:

Frame type	#num	Description
Configuration downlink	3	Used to update the node parameters. After the customer sets up a new node configuration in the Remote Configuration Form a new "Configuration downlink" frame is enqueued into the LoRaWAN network server's downlink queue.
RTC sync frame	6	Used to sync the node's RTC to the server's timestamp. It is the mandatory response to "Start frame 1" and "RTC update request" uplink frames.

The uplink frames are 11-byte long to always comply with the LoRaWAN datarate worst case scenario. Their structure consists on 2 parts: header and payload. The "header" format is always the same for all uplink frame types. On the other hand, the "payload" format may be different for each frame type.

Header	Payload
2 bytes	9 bytes

Regarding the downlink frames, they have variable length and its format is private to the customer. The "RTC sync frame" is the mandatory response for both "Start Frame 1" and "RTC update request" frames. The "RTC sync frame" provides the server time to the nodes in order to keep the RTC updated. Also, the "Configuration downlink" is an asynchronous frame sent by the server when the Remote Configuration Form is managed by the customer.

You must keep in mind that when a downlink packet is requested there are usually some issues related to LoRaWAN

network latency. This implies that the 1st request attempt usually fails. In that case, a 2nd attempt is sent in order to retrieve the lost downlink packet. For this reason, you might see that a couple of "Start Frame 1" or "RTC update request" frames are sent sequentially during the execution of the program.

### 3.6.2. Frame header

The "Header" included in each uplink frame contains 2 bytes:

Byte	Bit	Field
0	7	Parking lot status
0	6	Battery state
0	5	Configuration uplink acknowledgement
0	4	Sensor recalibration
0	3-0	Frame type
1	7-0	Sequence number

The meaning of each field is:

- Parking slot status:
  - 0: Free
  - 1: Occupied
- Battery status:
  - 0: OK
  - 1: Warning. The battery level measured is below the warning threshold (3340 mV)
- Configuration uplink frame acknowledgement status:
  - 0: ACK
  - 1: NACK
- Sensor recalibration:
  - 0: No calibration was done since the last uplink
  - 1: At least one calibration was done since the last uplink
- Frame type: Number related to frame type
  - 0: Info frame
  - 1: Keep-alive frame
  - 2: Configuration uplink frame
  - 3: Configuration downlink
  - 4: Start frame 1
  - 5: Start frame 2
  - 6: RTC sync frame
  - 7: RTC update request
- Sequence number: This is a 1-byte field so the sequence number goes from 0 to 255. When 255 is reached, the counter starts from zero again.

### 3.6.3. Frame payload

The "Payload" contents vary depending on each frame type.

The Start frame 1 frame contents are:

- Header ("Parking slot status" does not provide valid data)
- Firmware version:
  - From 1 to 8: Not released firmware versions
  - 9: v1.0.0
  - 10: v1.0.1
  - 11: v1.0.2 (last stable version)
- Battery level
- Radar settings (threshold and range)
- LoRaWAN settings (join mode and ADR)

The Start frame 2 frame contents are:

- Header ("Parking slot status" does not provide valid data)
- Sleep and Keep-alive time settings
- Night-mode settings (enabled/disabled, start hour, duration, sleep time, keep-alive time)

The Info frame contents are:

- Header
- Sensor error
- Temperature
- Timestamp (hour and minutes)
- Radar measurement (Distance, amplitude and number of reflections)

The Keep-alive frame contents are:

- Header
- Sensor error
- Temperature
- Timestamp (hour and minutes)
- Radar measurement (Distance, amplitude)
- Battery level

The RTC update request frame contents are the same as Keep-alive frame.

**Important:**

*The Customer Server provides the needed source code to parse this data into a more comprehensive structure. The Libelium Cloud Bridge also provides the needed tools to transmit the parsed data to a 3rd party IoT cloud. For more information, please refer to the ["Customer Server"](#) section.*

### 3.6.4. Node program flowchart

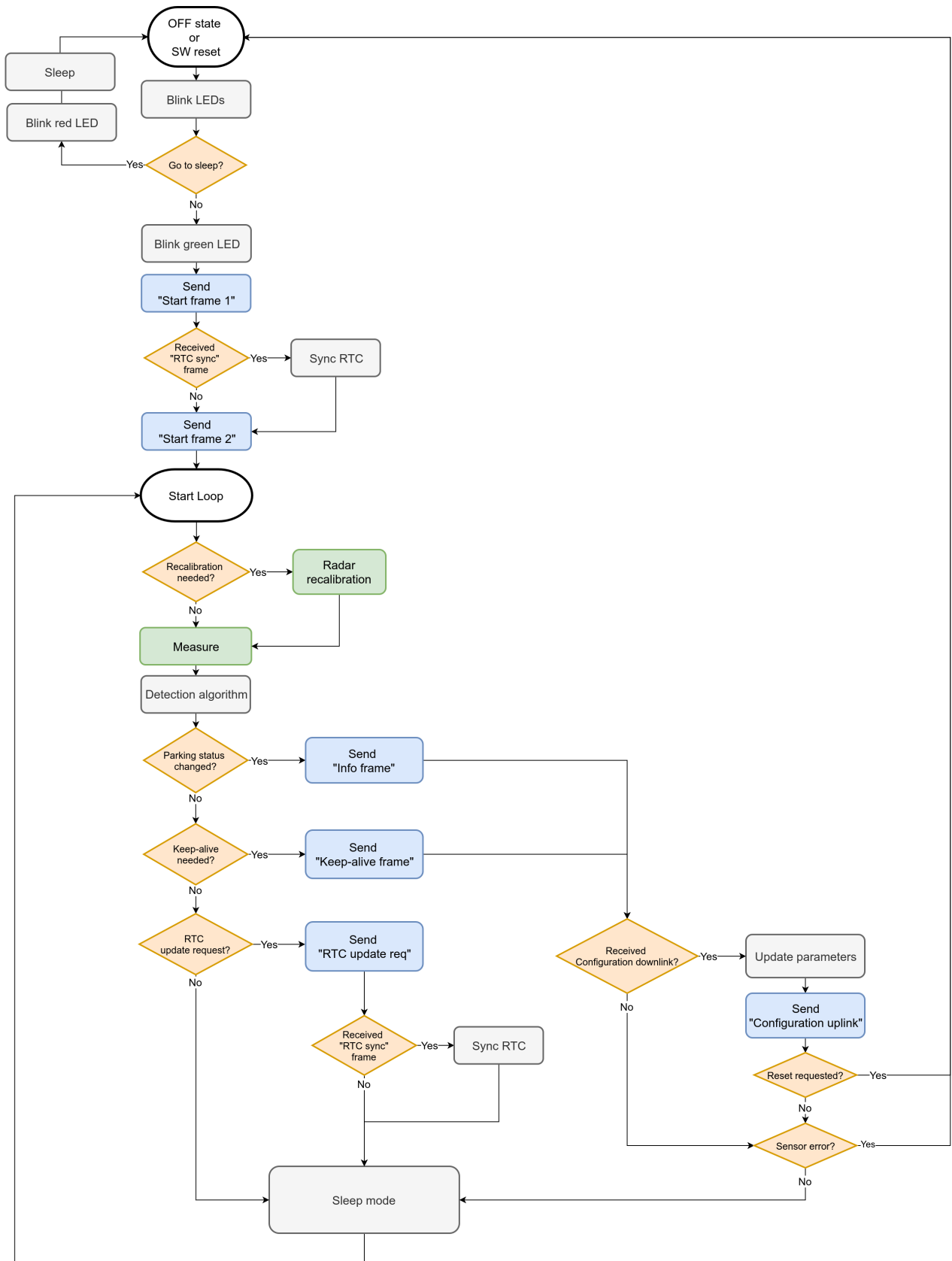

Figure : Smart Parking node program flowchart

## 3.7. Node parameters

### 3.7.1. Parameters description and ranges

The Smart Parking node has different parameters that change the timing and detection performance of the node. The next table shows the node parameters:

Parameter	Range	Description
Sleep time	1-10 min or 20-59 s	Minutes or seconds elapsed between each measurement cycle
Keep-alive time	0.5, 1, 2,..., 24 hour	Hours elapsed since last uplink message which triggers a new Keep-alive frame
Night-mode	0 or 1	Night-mode disabled/enabled
Night-mode start	0, 1,..., 23 hour	Night-mode starts when RTC reaches this parameter field
Night-mode duration	1, 2,..., 15 hour	Night-mode period is equal to this field
Night-mode sleep	1, 2,..., 10 min	Sleep time applied during night-mode
Night-mode keep-alive	1,..., 15 hour	Keep-alive time applied during night-mode
Radar range start	20 to 50 cm	Starting measurement distance (objects below this value are not detected)
Radar range length	50 to 100 cm	Range of measurement to be added to "range start" value
Radar threshold	5 to 100	Threshold used in detection algorithm, so higher threshold imply less sensitive detection
LoRaWAN join mode	0 (ABP) or 1 (OTAA)	Join mode used by the LoRaWAN radio module
LoRaWAN DevEUI	8-byte identifier	Defines the device EUI used by the LoRaWAN radio
LoRaWAN DevAddr	4-byte identifier	Defines the device address used by the LoRaWAN radio in ABP mode
LoRaWAN NwkSKey	16-byte key	Defines the LoRaWAN Network Session Key used by the LoRaWAN radio in ABP mode
LoRaWAN AppSKey	16-byte key	Defines the LoRaWAN Application Session Key used by the LoRaWAN radio in ABP mode
LoRaWAN AppKey	16-byte key	Defines the LoRaWAN Application Key used by the LoRaWAN radio in OTAA mode
LoRaWAN AppEUI	8-byte identifier	Defines the LoRaWAN Application EUI used by the LoRaWAN radio in OTAA mode
LoRaWAN port	1 to 223	Defines the port used for uplink sendings
LoRaWAN ADR	0 (off) or 1 (on)	Defines if Adaptive Data Rate is enabled or disabled
LoRaWAN RX1 Delay	0 to 65536	Defines the delay after first LoRaWAN rx window
LoRaWAN Subband	8-bit bitmap	Defines the sub-band used by the LoRaWAN radio (only applies to US and AU versions)

**Important:**

*The LoRaWAN identifiers and keys must be registered in the LoRaWAN network server before starting the node in order to receive data. For OTAA mode: DevEUI, AppEUI and Appkey. For ABP mode: DevEUI, DevAddr, NwkSKey and AppSKey.*



### 3.7.2. Understanding Info and Keep-alive frames

In the regular working mode (day-mode), "Sleep" and "Keep-alive" parameters are used. So the node normally sleeps for a specific "Sleep" time then wakes-up, measures and applies the algorithm detection in order to detect changes in the parking slot.

If a change is detected from 'free' to 'occupied' or viceversa, then an "Info" frame is sent. If no change occurred during the last "Keep-alive" time, then a Keep-alive frame is sent. Besides, if a sensor error is detected, a Keep-alive frame sending is forced in order to inform about this issue.

Example parameters used:

- Sleep: 7 minutes
- Keep-alive: 1 hour

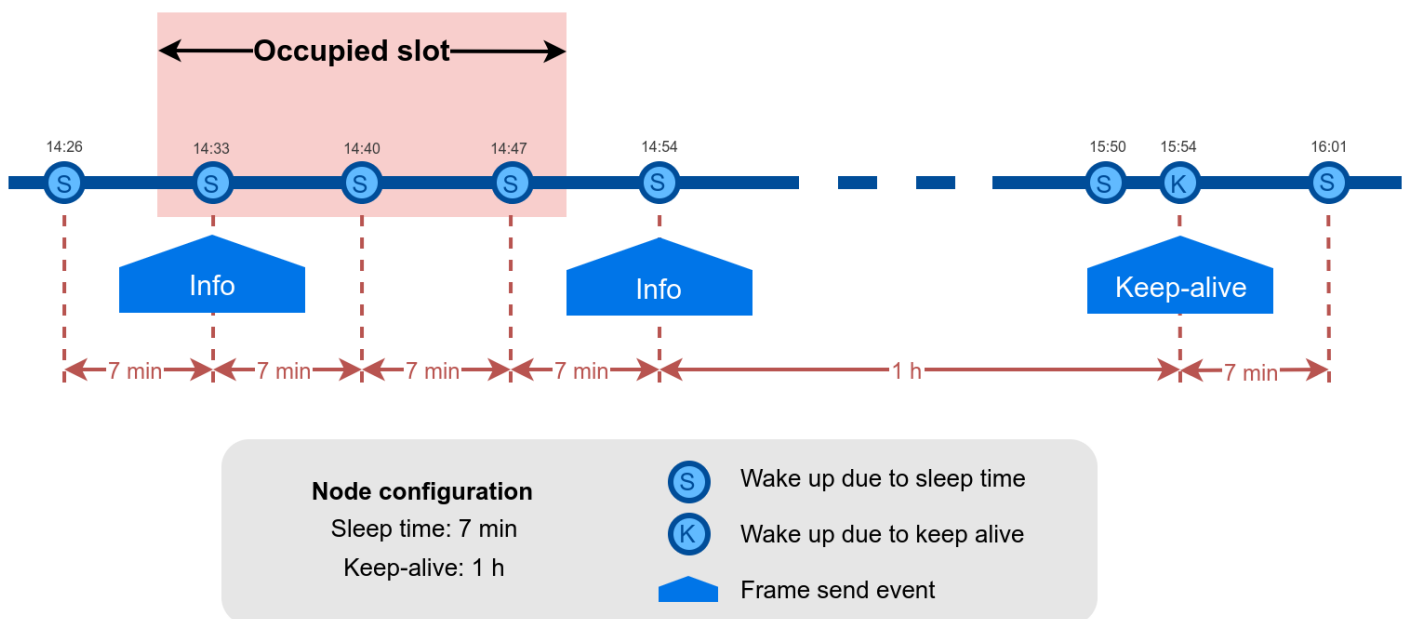

Figure : Example Info and Keep-alive frames

### 3.7.3. Understanding night-mode

As shown in the parameters table, there are some parameters that allow the user to configure the node to use 2 working modes depending on time settings: day-mode and night-mode.

The night-mode is a secondary and optional working mode that allows the user to configure a different time basis parameters in order to reduce the battery impact. So, it was developed to use it when the parking slot is expected to have fewer changes (i.e. at night). Therefore, different night-mode "Sleep" and "Keep-alive" settings are used.

It is not mandatory to use the night-mode during night. This mode is thought to be used when less vehicle movement is expected in the parking slots. Which could be during day time.

Example:

- Day-mode:
  - Sleep: 1 minute
  - Keep-alive: 1 hour
- Night-mode:

- Night-mode start hour: 21 hours (9 PM)
- Night-mode duration: 10 hours (Night-mode goes from 9 PM to 7 AM)
- Night-mode sleep time: 10 minutes
- Night-mode keep-alive: 10 hours

In the example, from 9 PM to 7 AM, the node will waste less battery because measurements are done every 10 minutes instead every minute. Something similar happens to the keep-alive events. If no parking slot change occurred during the night-mode, keep-alive events will happen every 10 hours instead every hour.

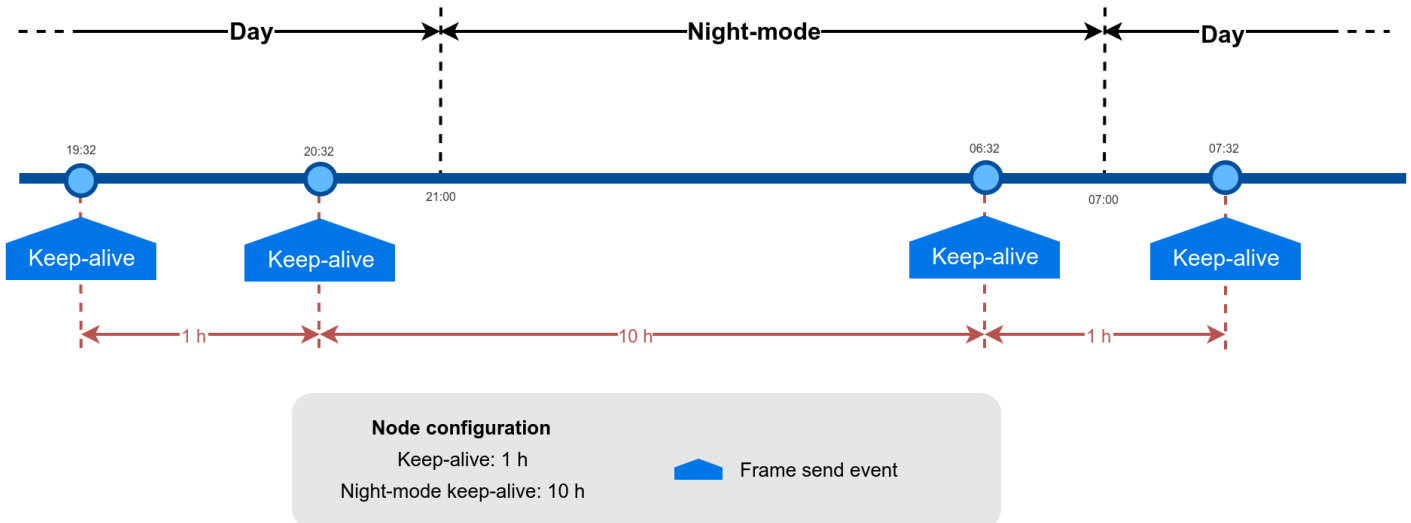

Figure : Example of day and night mode

**Note:** The conclusion is that the Night-mode is interesting for customers who certainly know the parking slot is expected to have fewer changes during large periods of time every day.

### 3.7.4. Understanding RTC synchronization

There are specific frame types that allow the node to synchronize the RTC to the server timestamp.

The "Start Frame 1" expects an answer from the server with the timestamp (hours and minutes). This frame is sent after starting the node or a software reset.

Besides, the node's firmware provides a mechanism which an "RTC update request" frame is sent every 24 hours since the node was started or reset. This frame waits for a downlink frame which brings the current server timestamp (hour and minutes).

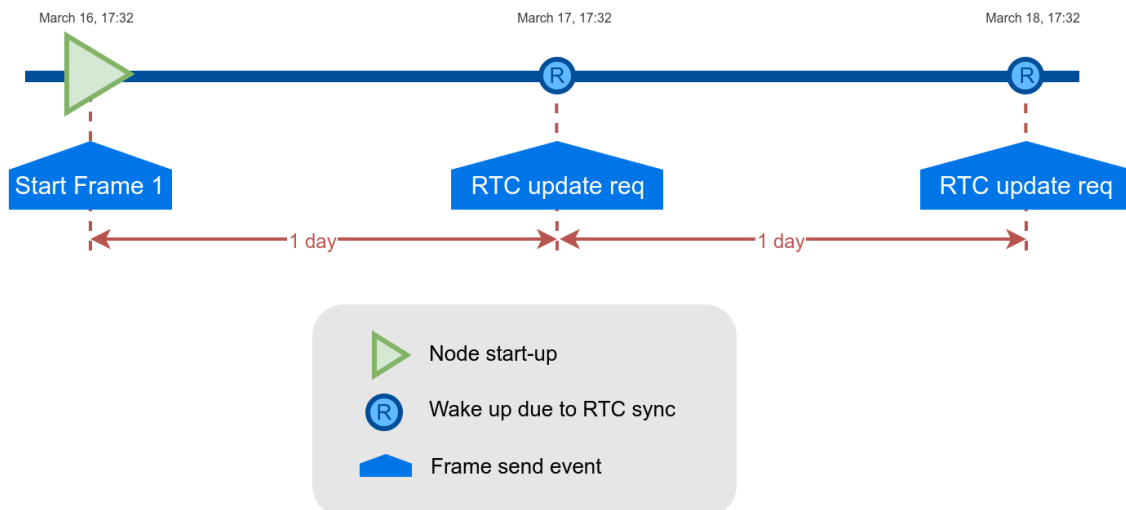

Figure : Example of RTC sync

**Note:** The RTC sync is important for Night-mode only where it mandatory to operate with a correct timestamp in order to enter and exit from night-mode to day-mode and viceversa.

### 3.7.5. Understanding uplink frames format (real example)

The next table shows all frames sent by a single node since it was started. The different columns display the parsed data from the received "uplink data".

Example:

- Day-mode:
  - Sleep: 1 minute
  - Keep-alive: 0.5 hour
- Night-mode:
  - Night-mode start hour: 22 hours (10 PM)
  - Night-mode duration: 8 hours (Night-mode goes from 10 PM to 6 AM)
  - Night-mode sleep time: 5 minutes
  - Night-mode keep-alive: 2 hours

It is possible to distinguish the starting frames at the beginning of the execution. Then the node informs with a new Keep-alive every 30 minutes. Any change of Parking slot status implies a new Info frame. And after 24 hours working, you can see the RTC request performed by the node.

Timestamp	Uplink data	F. Type	Parking lot	Battery	Recalibration	Sequence
04/15/19 15:59	040009c419143c01000000	4	NULL	0	0	0
04/15/19 15:59	0501010000011608050200	5	NULL	0	0	1
04/15/19 15:59	110200170f3b00000000b0	1	0	0	1	2
04/15/19 16:29	01030013101d00000000c8	1	0	0	0	3
04/15/19 16:59	01040013103b00000000c8	1	0	0	0	4
04/15/19 17:29	01050012111d00000000c8	1	0	0	0	5
04/15/19 17:59	01060010113b00000000c8	1	0	0	0	6

04/15/19 18:29	0107000f121d00000000c7	1	0	0	0	7
04/15/19 18:59	0108000e123b00000000d5	1	0	0	0	8
04/15/19 19:29	1109000d131d00000000d4	1	0	0	1	9
04/15/19 19:59	010a000c133b00000000d4	1	0	0	0	10
04/15/19 20:29	010b000b141d00000000d5	1	0	0	0	11
04/15/19 20:59	010c000b143b00000000d4	1	0	0	0	12
04/15/19 21:29	010d000a151d00000000d4	1	0	0	0	13
04/15/19 22:00	010e000a153b00000000d4	1	0	0	0	14
04/16/19 00:00	010f000a173b00000000d5	1	0	0	0	15
04/16/19 02:00	01100009013b00000000d5	1	0	0	0	16
04/16/19 04:00	01110009040000000000d4	1	0	0	0	17
04/16/19 06:00	01120008060000000000d5	1	0	0	0	18
04/16/19 06:04	8013000906040172410005	0	1	0	0	19
04/16/19 06:34	81140009062201754238ca	1	1	0	0	20
04/16/19 07:04	81150009070401704120d1	1	1	0	0	21
04/16/19 07:34	811600090722016f40b0d4	1	1	0	0	22
04/16/19 08:04	8117000a0804016d4268d4	1	1	0	0	23
04/16/19 08:34	8118000a0822016a3e50d4	1	1	0	0	24
04/16/19 09:04	8119000a090401743ec8d4	1	1	0	0	25
04/16/19 09:34	811a000b0922016d4160d4	1	1	0	0	26
04/16/19 10:04	811b000b0a04017b3e00d4	1	1	0	0	27
04/16/19 10:34	811c000b0a22016e4120d4	1	1	0	0	28
04/16/19 11:04	811d000c0b04017641d0d4	1	1	0	0	29
04/16/19 11:34	811e000c0b22016d41f8d4	1	1	0	0	30
04/16/19 12:04	811f000c0c04016d3e58d4	1	1	0	0	31
04/16/19 12:34	8120000d0c22016b3ea8d4	1	1	0	0	32
04/16/19 13:05	8121000e0d04016f3de8d4	1	1	0	0	33
04/16/19 13:35	8122000e0d23016f3e68c7	1	1	0	0	34
04/16/19 14:05	8123000e0e05016f3e80d4	1	1	0	0	35
04/16/19 14:35	8124000e0e2301af3de8c7	1	1	0	0	36
04/16/19 15:05	8125000e0f05016c3e50d5	1	1	0	0	37
04/16/19 15:35	8126000f0f2301703dd8c7	1	1	0	0	38
04/16/19 15:58	8727000f0f3b016b3dd0d4	7	1	0	0	39
04/16/19 15:59	8728000f0f3b016b3dd0d4	7	1	0	0	40
04/16/19 16:29	8129000f101c016e3c98c7	1	1	0	0	41
04/16/19 16:32	002a000f101f0000000000	0	0	0	0	42
04/16/19 17:02	012b0010110100000000c7	1	0	0	0	43

04/16/19 17:32	012c0011111f00000000c8	1	0	0	0	44
04/16/19 18:02	012d0010120100000000c7	1	0	0	0	45

### 3.7.6. Factory default values

Libelium provides all Smart Parking nodes with factory default parameters.

Parameter	Default value
Sleep time	1 min
Keep-alive time	2 hour
Night-mode	0 (disabled)
Night-mode start	0 hour
Night-mode duration	6 hour
Night-mode sleep	5 min
Night-mode keep-alive	4 hour
Radar range start	20 cm (should not be changed)
Radar range length	60 cm (should not be changed)
Radar threshold	25 (should not be changed)
LoRaWAN join mode	1 (OTAA)
LoRaWAN DevEUI	unique factory default value
LoRaWAN DevAddr	unique factory default value
LoRaWAN NwkSKey	unique factory default value
LoRaWAN AppSKey	unique factory default value
LoRaWAN AppKey	unique factory default value
LoRaWAN AppEUI	unique factory default value
LoRaWAN port	3
LoRaWAN ADR	0 (off)
LoRaWAN RX1 Delay	1000 (should not be changed)
LoRaWAN Subband	8-bit bitmap

### 3.7.7. Configure new parameter values

The Smart Devices App and the Remote Configuration Form allow the user to configure new parameters to the node. The 1st one is a desktop Java application which implies opening the node enclosure and plug a micro-USB cable to the node. The 2nd one is a form allocated in the Libelium Cloud or Customer Server which permits to remotely change some of the node parameters.

Regarding the time and sensor parameters, the same values are set to all nodes manufactured by Libelium. The default values can be seen in the previous section. However, the customer can configure the time and sensor settings using both Smart Devices App and Remote Configuration Form.

Regarding the LoRaWAN parameters, all keys are randomly generated for each node and kept secret. The DevEUI set to the node is the LoRaWAN hardcoded EUI which is unique for each radio chipset. However, the client can

configure/modify all LoRaWAN parameters using the Smart Devices App only (the Remote Configuration Form does not permit it).

**Note:** For further information about this matter please refer to the [“Smart Devices App”](#) and [“Remote Configuration Form”](#) sections.



# 4. Libelium Cloud management

## 4.1. Introduction to the Libelium SCM

According to the Smart Parking network architecture, users can select between 2 ways of working with the Smart Parking nodes: one using the Customer Server, and the other using the Libelium Cloud. Regardless of the solution chosen, users will always need to operate with the Services Cloud Manager (SCM), which is part of the Libelium Cloud.

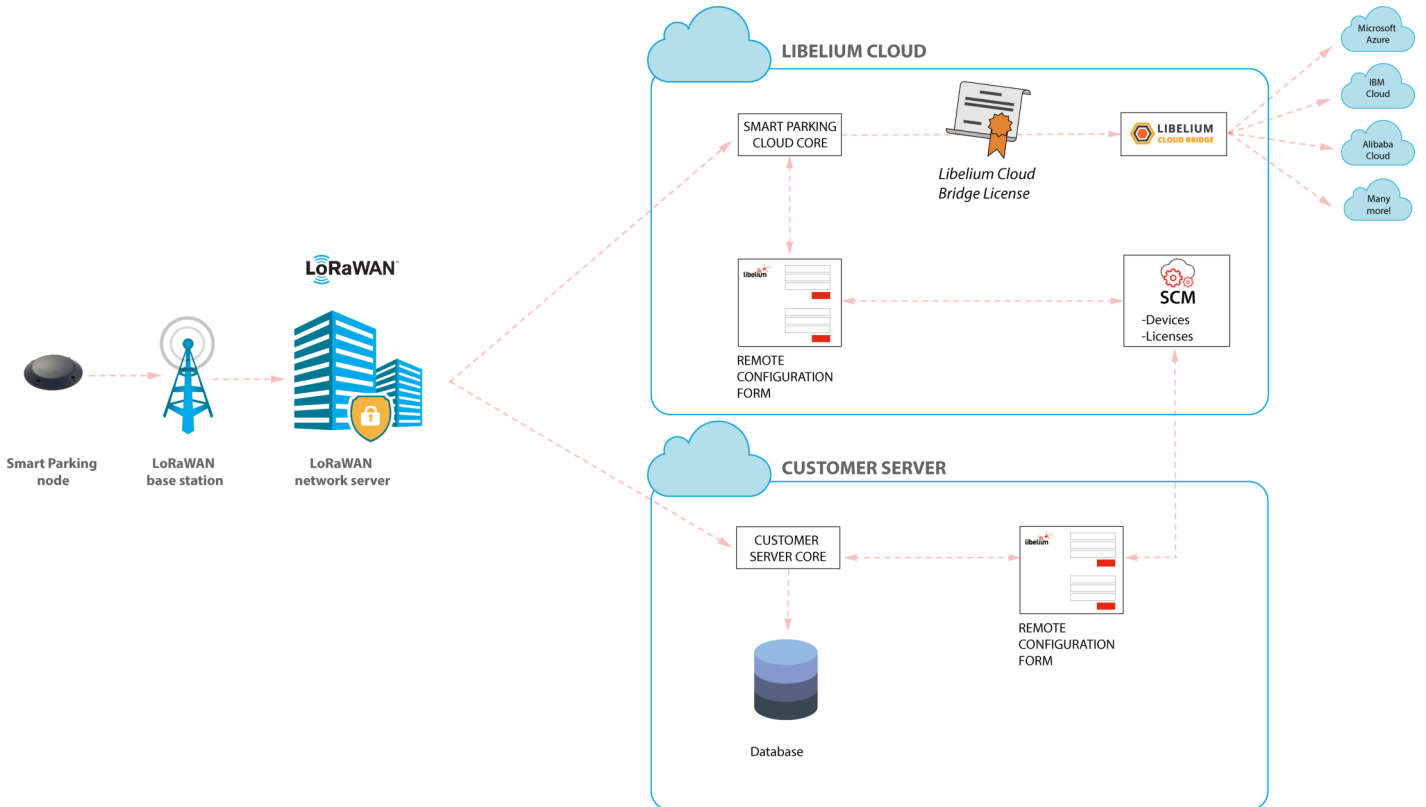

Figure : Smart Parking network architecture

## 4.2. SCM account

This is the 1st step users must follow. Anyone can create a new account in the SCM for free. This account will allow you to manage your Libelium devices and also all your licenses and services. You can access to the SCM at <https://cloud.libelium.com>.

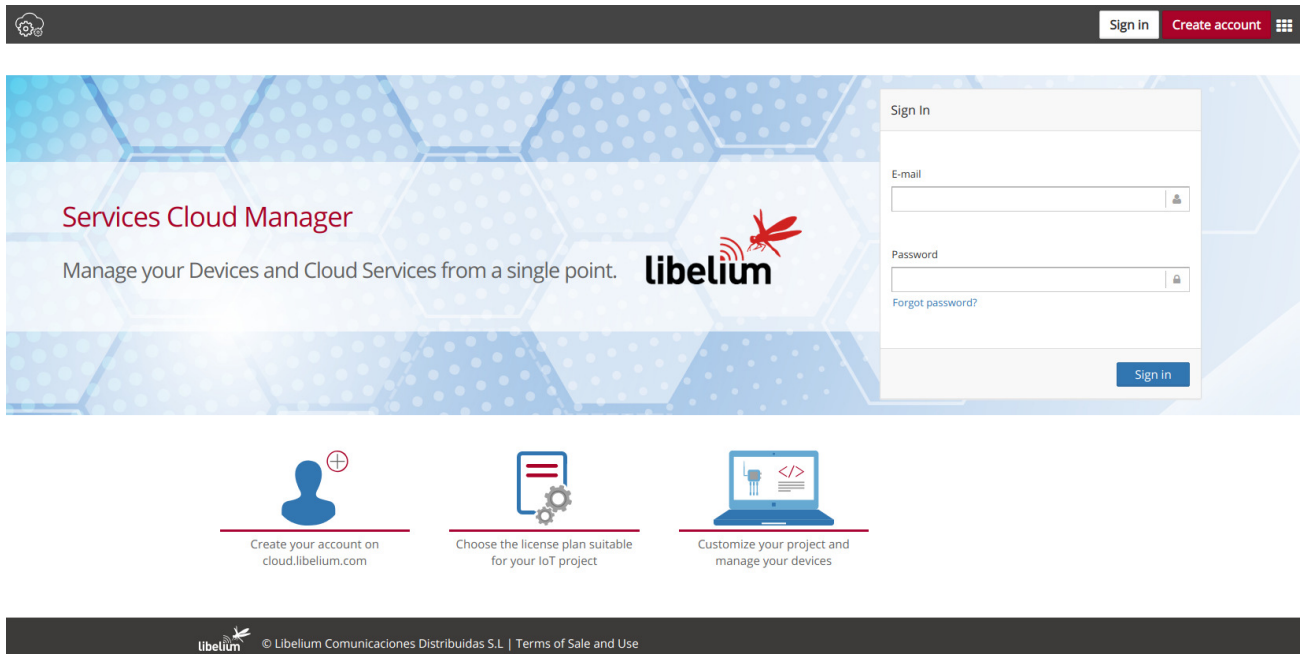

Figure : SCM Home page

### 4.2.1. Creating an account

To register and set up a password, go to <https://cloud.libelium.com/register> and click on "Create account".

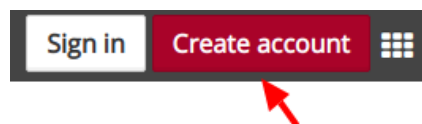
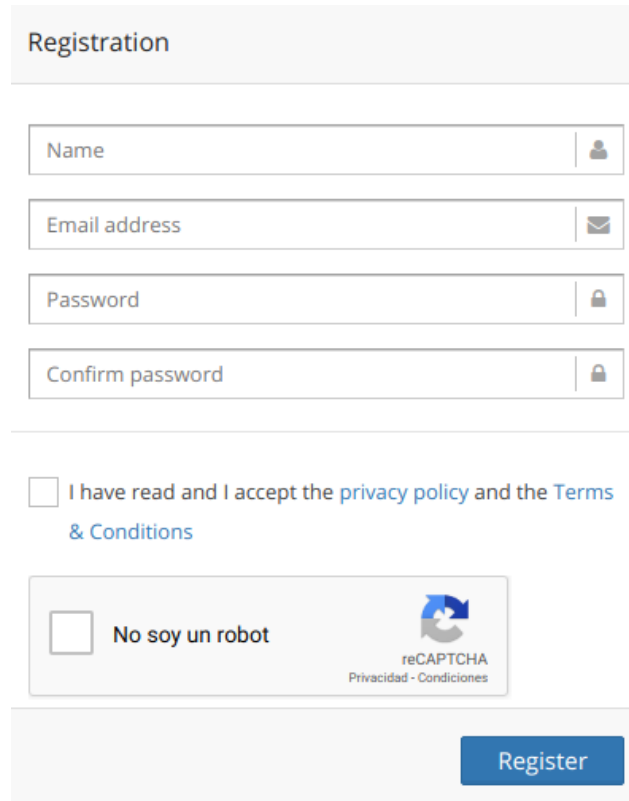

Figure : "Create account" button

Complete the information in the form (all the fields are mandatory):

- Name: Your name
- E-mail address: A valid e-mail address, it will be used for verification purposes
- Password and Confirm password: Set your password

Accepting Terms & Conditions is also mandatory to create a new account in the SCM.



The registration form is titled "Registration" and contains the following fields and elements:

- Name field with a user icon on the right.
- Email address field with an envelope icon on the right.
- Password field with a lock icon on the right.
- Confirm password field with a lock icon on the right.
- A checkbox with the text "I have read and I accept the [privacy policy](#) and the [Terms & Conditions](#)".
- A reCAPTCHA widget with the text "No soy un robot" and the reCAPTCHA logo.
- A blue "Register" button at the bottom right.

Figure : Create account form

## 4.2.2. Signing in

To sign in the SCM, go to the [Libelium Cloud](#) and click on the "Sign In" button.

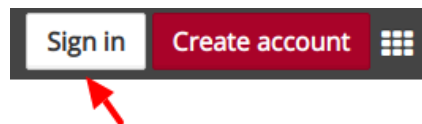
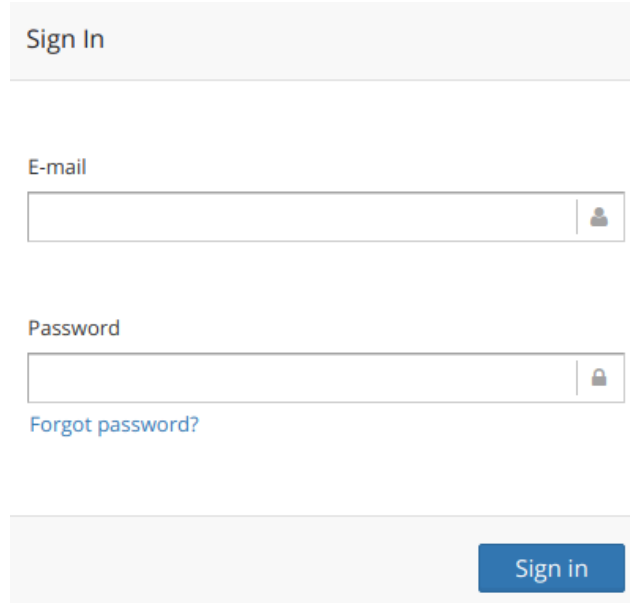

Figure : "Sign-in" button

Complete the information in the form. The e-mail and password used when creating the account will be required:

- E-mail address: E-mail address used for registration
- Password: Password used for registration



Sign In

E-mail

Password

[Forgot password?](#)

Sign in

Figure : Sign-in form

The Terms & Conditions accepted when creating the account apply for any time you sign in the SCM. If you do not have an account yet, follow the steps described on the section "Create an account" to obtain valid credentials. If you already created an account and need a password reminder, you can click on "Forgot password?".

### 4.3. Smart Parking nodes registration

After placing an order including Smart Parking nodes you should receive an e-mail with the activation codes for all your devices. In this e-mail you will directly find links to register the devices in the Libelium Cloud.

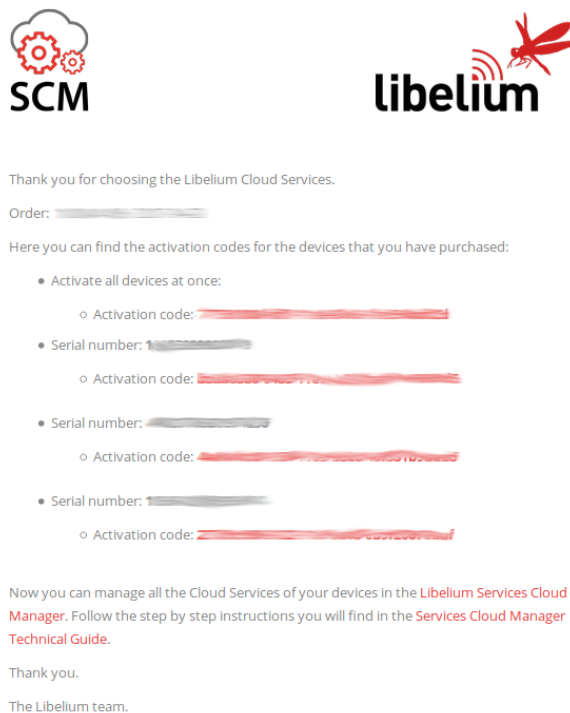

Figure : Activation codes e-mail

By clicking on these links you will be able to complete the registration process by following the wizard:

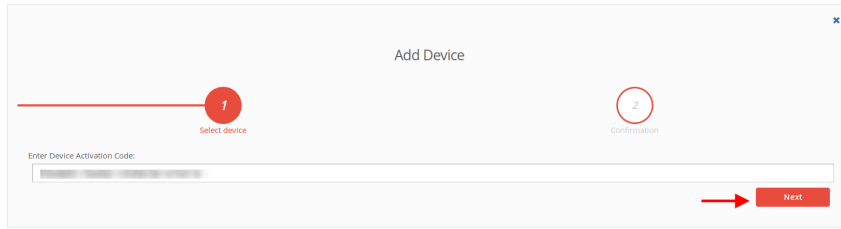

Figure : Step1. Enter device activation code

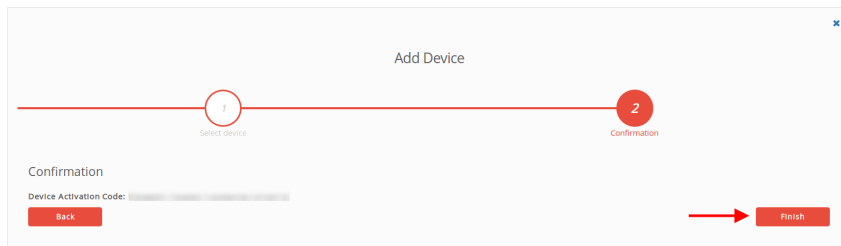







Figure : Step2. Confirm activation

## 4.4. Editing Smart Parking nodes

You can change the "name", "project", "description" and (if the device is a Smart Parking node) the "LoRaWAN EUI" of the device by clicking the pencil icon located next to the each device. Finally you must save the changes.

<input type="checkbox"/>		[blurred]	Smart Parking	[blurred]	Smart Par
<input type="checkbox"/>		[blurred]	Smart Parking	[blurred]	Smart Par
<input type="checkbox"/>		[blurred]	Smart Parking	[blurred]	Smart Par
<input type="checkbox"/>		[blurred]	Smart Parking	[blurred]	Smart Par
<input type="checkbox"/>		[blurred]	Smart Parking	[blurred]	Smart Par

**Edit Device** ✕

Name:

Project:

Description:

LoRaWAN EUI:

Figure : Edit a device

## 4.5. Export CSV file with nodes credentials

The Libelium Cloud allows the user to export all nodes credentials via HTTPS secure connection. The exported file is a CSV file with all credentials needed for OTAA join mode. The exported LoRaWAN credentials are the same as they were configured by factory default. This means that if the user changed the LoRaWAN credentials via "Smart Devices App", then the exported credentials will not be same.

In order to export the file, you must go to <https://cloud.libelium.com>, log in and then access "My Devices". On the website you will identify the "Smart Parking actions" button which permits to download the nodes credentials by clicking on the "Download nodes keys" button.

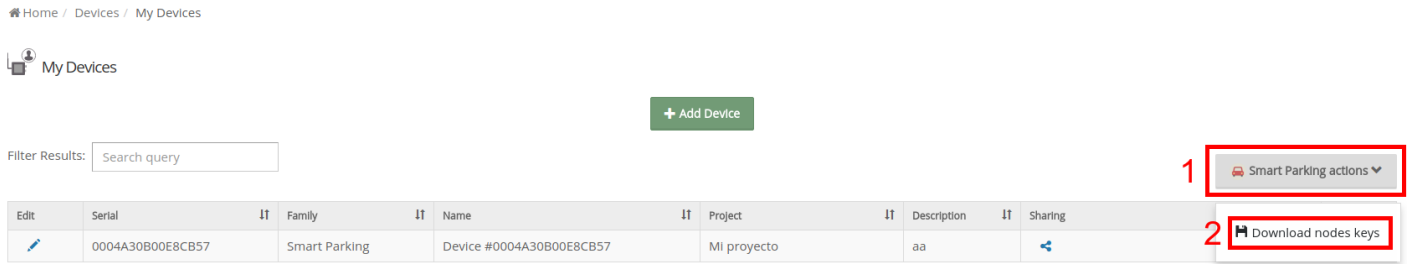

Figure : Export CSV file with all nodes credentials

The CSV file for 'N' devices exported from Libelium Cloud follows the next format:

```

<DevEUI_1>,<AppEUI_1>,<AppKey_1>,<Name_1>
<DevEUI_2>,<AppEUI_2>,<AppKey_2>,<Name_2>
<DevEUI_3>,<AppEUI_3>,<AppKey_3>,<Name_3>
...
<DevEUI_N>,<AppEUI_N>,<AppKey_N>,<Name_N>

```

## 5. Smart Devices App

Libelium Smart Devices App is a software tool developed by Libelium that allows users to install new firmware versions and program the configuration of the new Libelium devices in a few clicks. At the moment it is only available for Smart Parking and MySignals products, but the list will be incremented shortly.

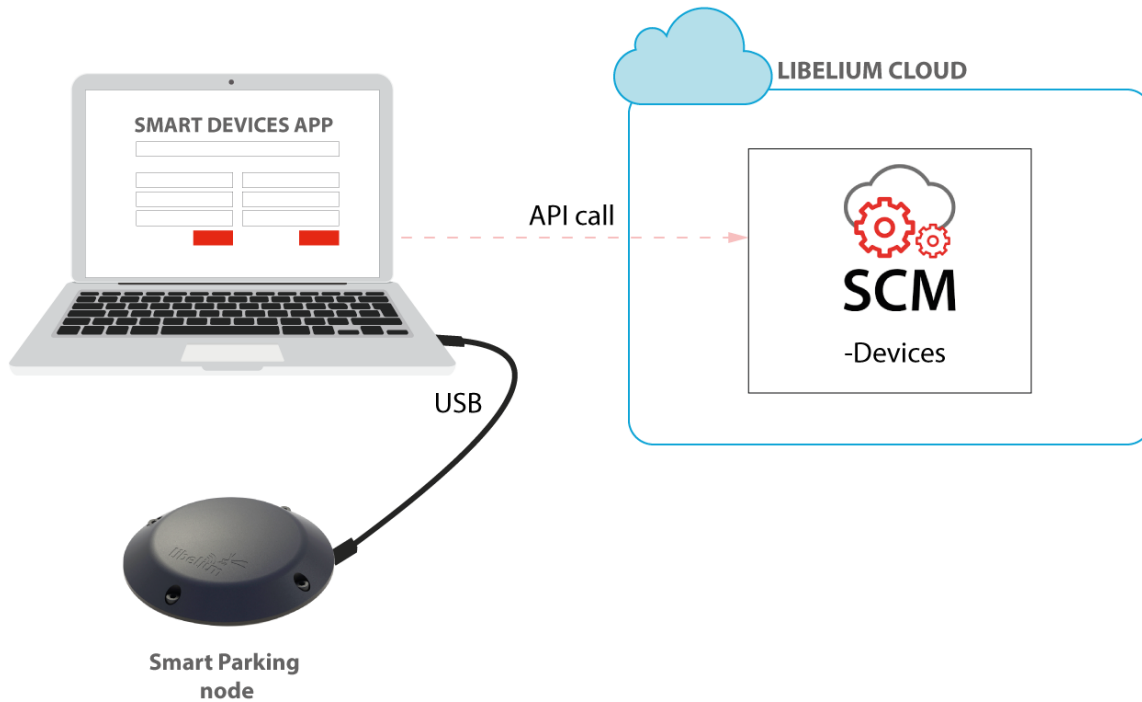

Figure : Smart Devices App is connected to the node via USB

### 5.1. How to install the Smart Devices App

First of all and before installing anything, users have to take into account the platform where the application is going to be installed. To install the Smart Devices App, it is compulsory to have installed the JDK 1.8. If it is not installed in the computer, you can download it from the website below and follow the steps described:

[https://docs.oracle.com/javase/8/docs/technotes/guides/install/install\\_overview.html](https://docs.oracle.com/javase/8/docs/technotes/guides/install/install_overview.html) .

Once installed JDK, users can download the application in the link below, selecting the appropriate operative system and architecture:

<http://www.libelium.com/development/smart-parking/software-and-applications>

Then customers only have to extract the content of the SmartDeviceApp zip file downloaded in a place with the right permissions, and finally execute the file called "SmartDeviceApp" that will initialize the application. Please, note that the extension of this file will depend on the operating system the user is using at the moment (.sh for Linux and OSX, and .bat for Windows).

This new Smart Devices App uses a new programmer under the hood called STM32CubeProgrammer, so it is a good practice to before using the Smart Devices App :

<https://www.st.com/en/development-tools/stm32cubeprog.html>

## Windows systems

It is important to install STM32CubeProgrammer as the software contains the drivers needed to set the USB ports in DFU mode, if you want to know more about how to install this software and know about how to set the USB in DFU mode, please see the official guide from STM32CubeProgrammer:

[Link to ST documentation.](#)

Make sure that your USB can switch to DFU mode, you can check it with the STM32CubeProgrammer.

## MacOS systems

It is not necessary to install additional software, but you can install STM32CubeProgrammer:

<https://www.st.com/en/development-tools/stm32cubeprog.html>

## GNU/Linux systems

It is necessary to change permissions to USB ports. If you have problems with your USB device on your GNU/Linux (or the Smart Devices App does not recognize the SmartParking v2 device) you can compile the *stlink driver discover*:

---

```
git clone https://github.com/texane/stlink.git stlink
cd stlink
make
# install binaries:
sudo cp build/Release/st* /usr/local/bin/
# install udev rules
sudo cp etc/udev/rules.d/49-stlinkv* /etc/udev/rules.d/
# and restart udev
sudo udevadm control --reload
```

---

If you have problems with stlink driver installation please refer this site: <https://github.com/texane/stlink>.

Review the UDEV rules and they should be as follows:

---

```
nano /etc/udev/rules.d/49-stlinkv2.rules
SUBSYSTEMS=="usb", ATTRS{idVendor}=="0483", ATTRS{idProduct}=="3748", \
  MODE=="0666", \
  SYMLINK+="stlinkv2_%n"
```

---

Add your user to **dialout**:

---

```
sudo addgroup <username> dialout
```

---

Then you will be able to use the USB ports on Linux systems. It is also recommended to install *STM32CubeProgrammer* for the current OS the user is running:

<https://www.st.com/en/development-tools/stm32cubeprog.html>

### 5.1.1. Start Smart Devices App on Windows

Go to the Smart Devices App folder and click on the file **SmartDevicesApp.bat**.



### 5.1.2. Start Smart Devices App on GNU/Linux

Open a new terminal window and navigate to the folder containing the Smart Devices App application, then type:

```
sudo ./SmartDevicesApp.sh
```

### 5.1.3. Start Smart Devices App on MacOSX

Open a new terminal window and navigate to the folder containing the Smart Devices App application, then type:

```
sudo ./SmartDevicesApp.sh
```

## 5.2. Upgrading the Smart Devices App

Occasionally, some improvements and new services will be released; if this is the case, the Smart Devices App will show a notification encouraging the user to go to the "Installation" section and download the new version.

**Important:**

*It is mandatory to have an active internet connection in order to use the Smart Devices App .*

To upgrade the Smart Devices App , you must follow the installation steps. This will overwrite the files from previous versions. As a 1st step, we recommend to backup the following files:

- `cfg/config.ini`: This file stores the Smart Devices App configuration parameters. To restore those settings, every single parameter value (username, password, etc) should be copied into the new version of the "config.ini" file. The file should not be overwritten, new parameters must be added and merging files is mandatory.
- `temp`: This folder contains the firmware files previously used. To restore these files, copy the content of the saved "temp" directory into the new version "temp" directory.

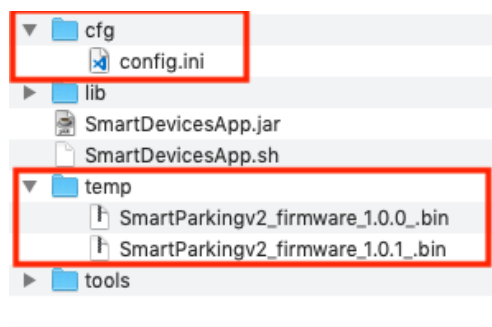

Figure : Smart Devices App files

## 5.3. Smart Parking v2

There is a new tab on the application for the new Parking version section called "Smart Parking v2 ". Inside the tab there are a lot of new characteristics and options to configure the Smart Parking v2 device.

The main sections are: Programmer, Firmware Update and Configuration.

### 5.3.1. How to plug the Smart Parking node

Before using the Smart Devices App, you must keep in mind how to plug and initialize it properly.

As explained in the “[Smart Parking node](#)” section, there are 2 switches to manage the node working mode. In order to use the node with the Smart Devices App, it is mandatory to set the node in “Boot” mode and then power it on. If you changed from “App” to “Boot” mode, then you can use the reset button to apply the change and restart the node in the bootloader section.

**Note:** Go to the “[User switches](#)” section for further information

**Important:**

*Never leave the device set to “On” and “Boot” for more time than needed: the bootloader does not provide any sleep mode and it will waste the battery of the device. So when you finish reconfiguring the device, please set the node to “Off” state.*

### 5.3.2. Configuration

In the last tab, called **Configuration**, 2 parameters are available: “Username” and “Password”. These are the same credentials needed for the Libelium Cloud (SCM, <https://cloud.libelium.com/login>).

Filling these fields is mandatory before start using the Smart Devices App with the Smart Parking node. Please remember to click the “Save” button at the bottom of the application to store the correct credentials.

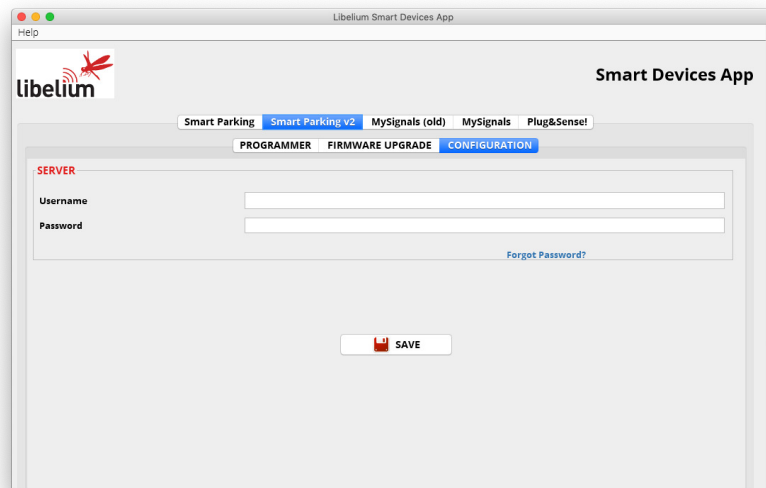

Figure : Configuration screen on Smart Parking v2

There are some differences between the 1st version and the 2nd one. In Smart Parking v2 you must type your credentials to authenticate your nodes against the Libelium Cloud.

**Note:** You should have an account on Libelium Cloud to get your username and password.

If you forgot your password you can always recover it by clicking on the “Forgot password?” link on the application:

<https://cloud.libelium.com/password/reset>

### 5.3.3. Programmer (change node parameters)

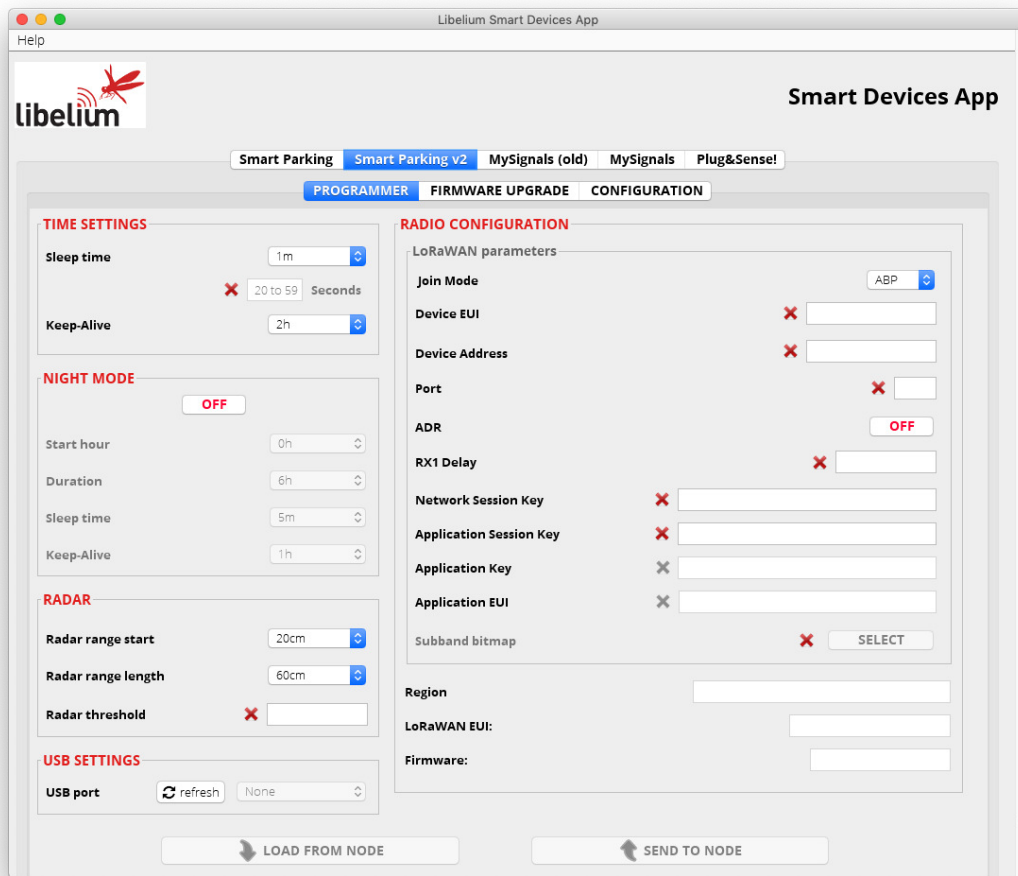

Figure : Smart Parking v2 Programmer section

Users can read and write all node parameters in this section. The process is quite simple: just connect the device to the computer where the Smart Devices App is installed using the USB cable provided and switch on the node in "Boot" mode.

Next, refresh the "USB settings" section (bottom-left corner), clicking the "Refresh" button. Then select the port where the device has been connected. After that it is a good practice to hit the "Load from node" button to get the current configuration from the connected Smart Parking v2 device.

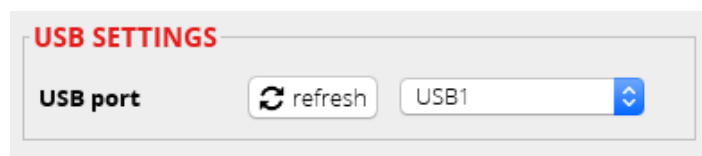

Figure : Smart Parking v2 USB settings

The "Load from node" button will read all parameters from the node and will display the information on the app. On the other hand, the "Send to node" button will overwrite the configuration on the node. All available fields have to be filled with the proper format. If any parameter does not have an acceptable format, a red cross like this **✗** is displayed close to it, and you will not be able to write the information on the node. If the information introduced is valid, a green tick **✓** is shown. When loading/sending information to the node, the application will warn the user through a pop-up window about the status of the operation.

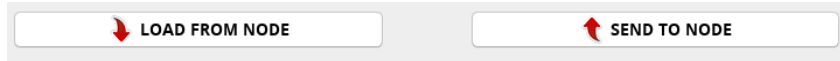

Figure : “Load configuration from node” & “Send configuration to node” buttons

Smart Parking v2 shares most of the configuration fields with Smart Parking v1 . However, it is important to know the purpose for each field on the Smart Parking v2 configuration. To know more about each field and how they work, please refer to the chapter “[Smart Parking node](#)”.

### 5.3.4. Firmware upgrade

Inside this tab, users can select the firmware version to install in their devices.

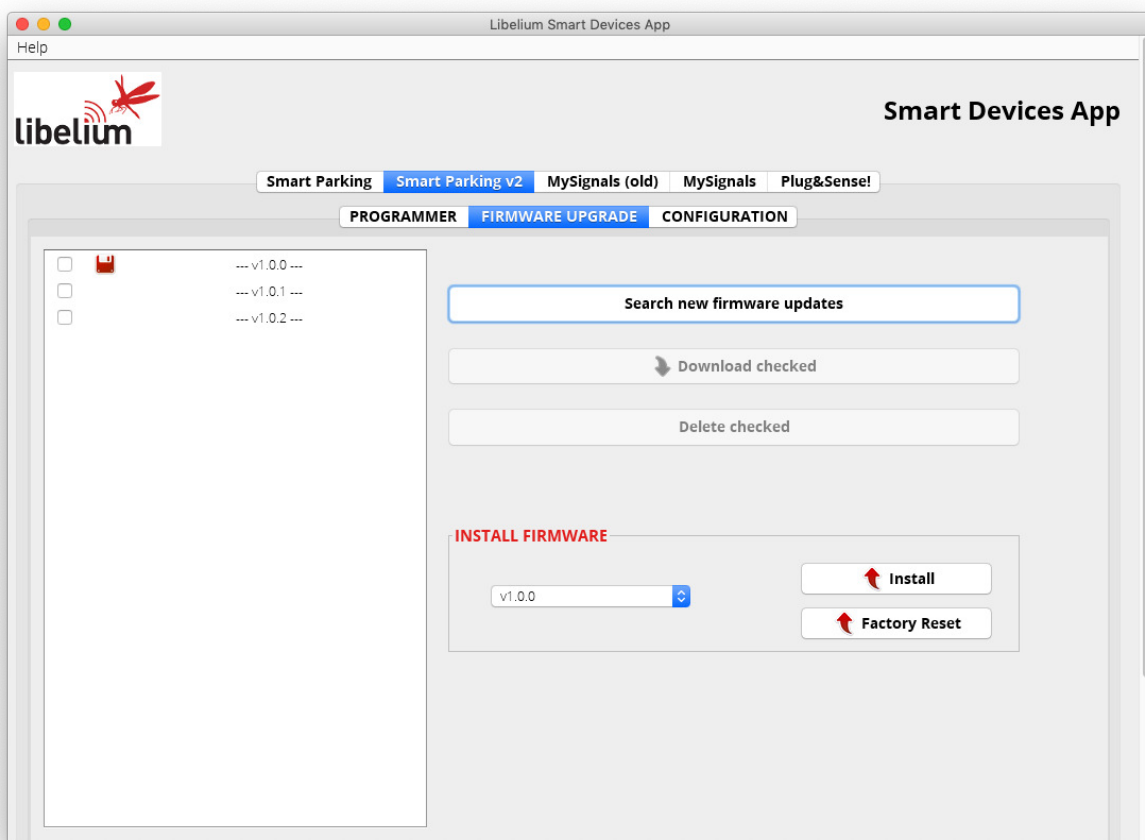

Figure : Firmware update and factory reset section for Smart Parking v2

The list with all available firmwares is loaded when the program starts, but users can manually update it by clicking on the “Search new firmware updates” button. Before installing the firmware, it is necessary to download it. This process is very simple, just mark the check of the version you want to install from the list  and click on “**Download checked**”.

To summarize, the steps are:

1. Click the “Search new firmware updates” button to load new firmware updates
2. Check one or more firmwares to download from the firmware list on the left side
3. Click on “Download checked” to download the selected firmwares



Figure : Download new firmware versions

Now the firmware files are downloaded. The drop-down menu will show the available firmware files to be installed on the node.

When the file is downloaded, a disk icon  is displayed close to it, indicating it is downloaded. On the “Install Firmware” section you can select the firmware to install and then hit on “Install” to execute the installation. The app will display a pop-up message for the status of the firmware installation.

**Note:** Remember that the USB port **must be selected** in the programmer tab

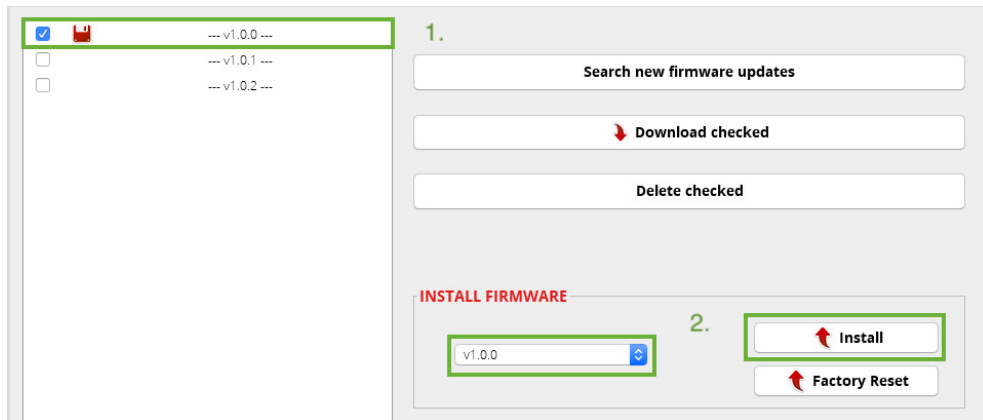

Figure : Firmware installation

You can also delete the downloaded firmware files by selecting the check box from the list and then clicking on the “Delete checked” button.

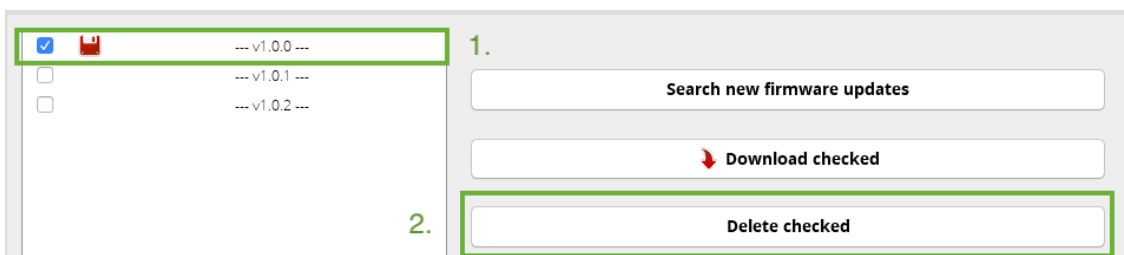

Figure : Firmware deletion process for Smart Parking v2

### 5.3.5. Factory Reset

The Factory Reset is the last option to recover a non-working SmartParking v2 device. It performs a full reset followed by a firmware and configuration reset. To get the recovery configuration file, send an e-mail to [tech@libelium.com](mailto:tech@libelium.com) pointing your Smart Parking v2 order number and the Technical Service Team will send the configuration file needed.

For this process it is mandatory to download a firmware, as explained on the previous section [“Firmware upgrade”](#). Then select a firmware from the drop-down menu and press the “Factory Reset” button.

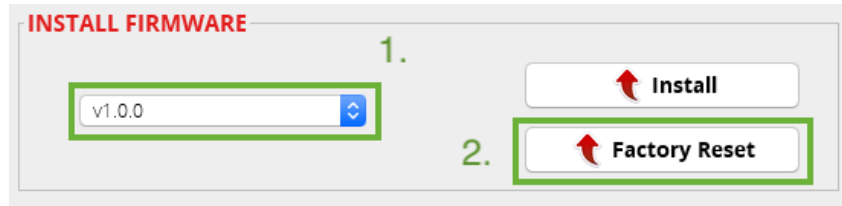

Figure : Factory reset process for Smart Parking v2 - Step 1

Pressing the “Factory Reset” button will display a file explorer window to select the configuration file provided by Libelium. Once you selected this file, a message will show up asking if you want to start the process. If the “Yes” option is selected, the Factory Reset process starts.

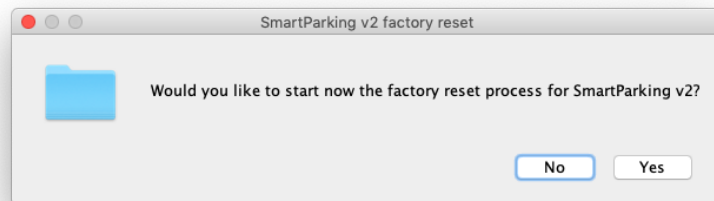

Figure : Factory reset process for Smart Parking v2 - Step 2

When the Factory Reset finishes, another message informs about the final result:



Figure : Factory reset finished for Smart Parking v2

After this process, you can configure your Smart Parking v2 node again on the “Programmer” tab.

## 6. LoRaWAN Network Server setup

Libelium currently supports two services in the Customer server application: **Loriot** and **Activity**. In this section, it is explained how to set them up with a simple configuration.

### 6.1. Loriot

This section explains how to route the information via Loriot network server to the "Customer server" using the HTTPS protocol.

**Important:**

*The free "Community account" does not permit remote downlinks. Therefore, a Commercial license should be purchased in order to use remote downlink messages for RTC sync, night-mode feature and node parameter update via Remote Configuration Form.*

#### 6.1.1. Log in

Log in in the [Loriot platform](#), selecting your server location.

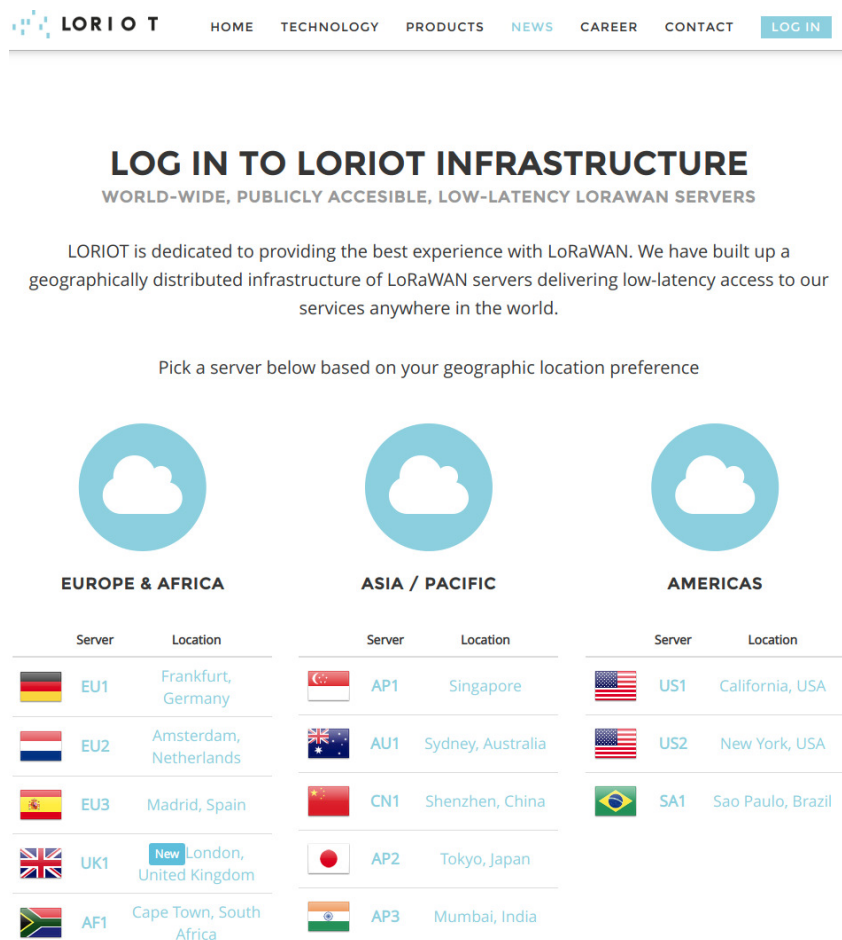

The screenshot shows the Loriot login page with a navigation bar and a main heading 'LOG IN TO LORIoT INFRASTRUCTURE'. Below the heading, there is a sub-heading 'WORLD-WIDE, PUBLICLY ACCESIBLE, LOW-LATENCY LORAWAN SERVERS'. A paragraph describes Loriot's infrastructure. A prompt asks the user to pick a server based on geographic location preference. Three server regions are listed: EUROPE & AFRICA, ASIA / PACIFIC, and AMERICAS. Each region has a table of server and location options.

EUROPE & AFRICA		
Server	Location	
	EU1	Frankfurt, Germany
	EU2	Amsterdam, Netherlands
	EU3	Madrid, Spain
	UK1	<span>New</span> London, United Kingdom
	AF1	Cape Town, South Africa

ASIA / PACIFIC		
Server	Location	
	AP1	Singapore
	AU1	Sydney, Australia
	CN1	Shenzhen, China
	AP2	Tokyo, Japan
	AP3	Mumbai, India

AMERICAS		
Server	Location	
	US1	California, USA
	US2	New York, USA
	SA1	Sao Paulo, Brazil

Figure : Loriot login web page

## 6.1.2. Create a new Lorient application

Once you selected the server location, a new prompt will be displayed asking your credentials. After logging in, users have to create a new application in the Lorient dashboard. To do this it is necessary to click on **"Applications"** in the left side bar and then in **"New Application"** option located in the same bar:

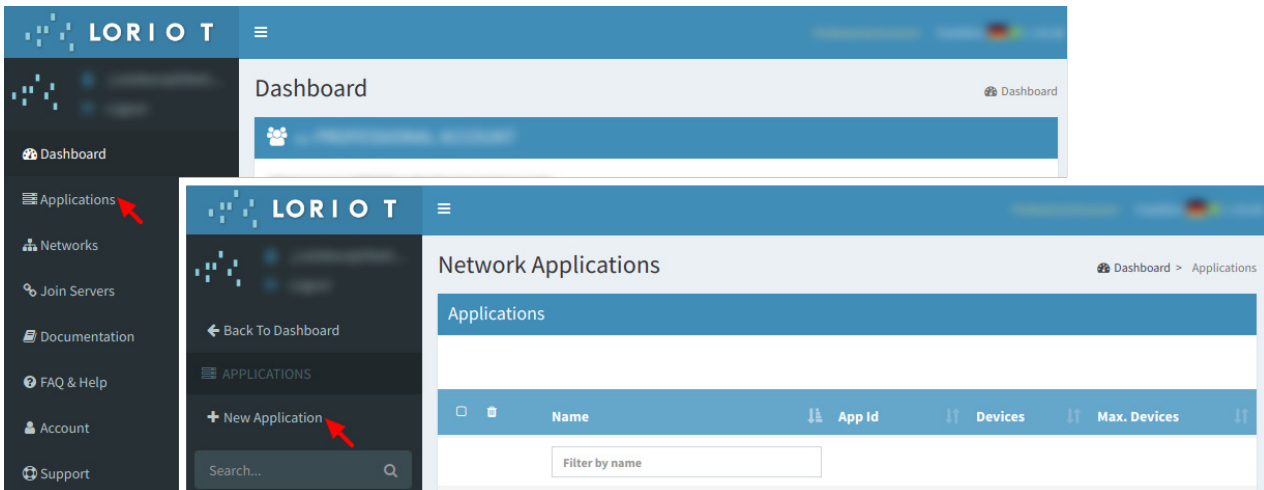
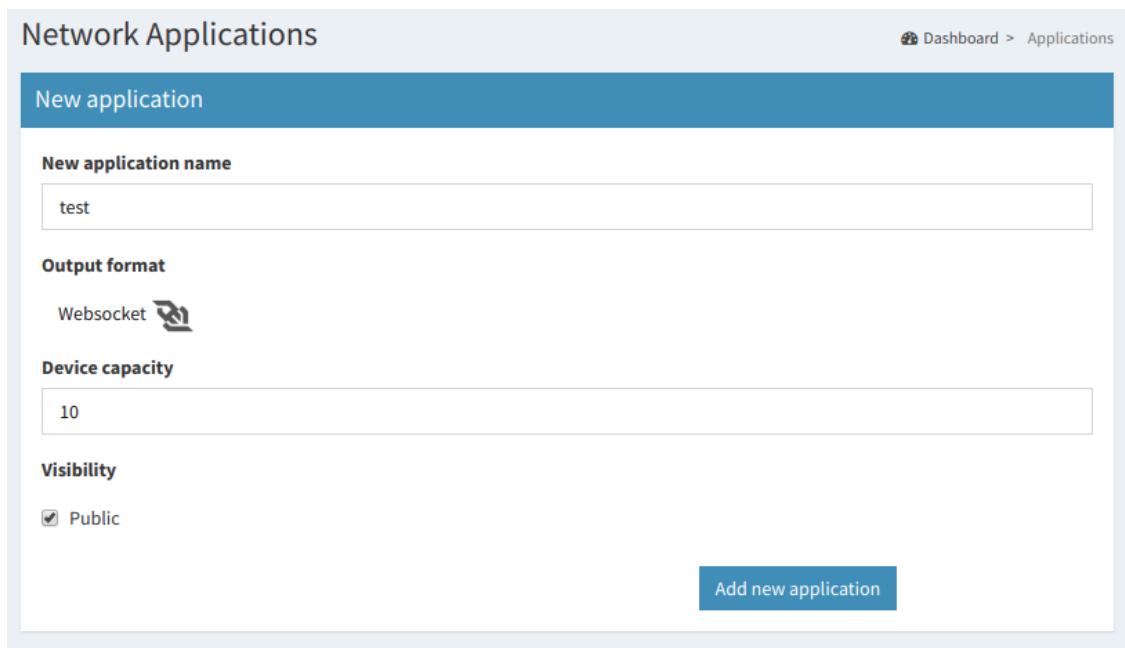

Figure : Creating an application

Fill the form in order to create the desired application in Lorient:

- **New application name:** Name to identify the application.
- **Output format:** "Websocket" is selected by default and it is not possible to change it in this form. How to change it will be explained in the following step.
- **Device capacity:** Maximum number of devices to be registered in this application. The maximum value will depend on the account type you have.
- **Visibility:** This checkbox permits to set the application as "public" or "private".

 The image shows the 'New application' form within the 'Network Applications' section of the dashboard. The form has a blue header 'New application' and contains the following fields:
 

- New application name:** A text input field containing the value 'test'.
- Output format:** A dropdown menu with 'Websocket' selected and a small icon to its right.
- Device capacity:** A text input field containing the value '10'.
- Visibility:** A checkbox labeled 'Public' which is checked.

 At the bottom right of the form is a blue button labeled 'Add new application'.

Figure : New application form



### 6.1.3. Manage Lorient output data

Once the application is created, the dashboard will be shown. Go to **"Application Outputs"** → click on **"Manage outputs"** → click on "Add new output":

The screenshot shows the 'Application /' dashboard. On the left, there's a sidebar with 'Network Application' details and 'Application Outputs' section. The 'Application Outputs' section has a 'Manage outputs' button highlighted with a red arrow. The main content area shows 'Application Output /' with a table of outputs. The table has columns: Output, Name, Mechanism, and Type. One output is listed: 'WebSocket' with mechanism 'Listen and wait' and type 'LORIIOT.io'. Below the table is an '+ Add new output' button highlighted with a red arrow. To the right, there's a 'WebSocket' mechanism details panel with the text 'How to use WebSocket with LORIIOT' and instructions to point a browser or library to the WebSocket URL.

Figure : Create a new application output

Select **"HTTP Push"** from the list and fill the form displayed on the right side. In the **"Target URL for POSTs"** field, write the URL where Lorient must send data to (i.e. `http://my_server.com/services/activity/`). Besides, users can add an authorization header in **"Custom Authorization header value"** in order to increase the security in the communications, so the final server only accepts the information from an authorized account. Finally, click on the **"Confirm change"** button to save the information.

The screenshot shows the 'Application Output /' configuration page. The title is 'Chose output type'. Below it, there's a question: 'Where should we feed your IoT data? See the Application API catalog for details'. A table lists various output types. The 'HTTP Push' type is selected and highlighted with a red arrow. To the right, the configuration form for 'HTTP Push' is shown. It includes a 'Setup guide' section with instructions to set up an HTTP server. Below that, there's a 'Setup parameters' section with two input fields: 'Target URL for POSTs' containing 'http://my\_server.com/service' and 'Custom "Authorization" header value' containing 'cn389ndrpi8741wurgjr'. Both fields are highlighted with red boxes. At the bottom, there are 'Confirm change' and 'Cancel' buttons.

Figure : Application output configuration

### 6.1.4. How to delete unused Lorient applications

A list with all application outputs will be displayed in the "Application Outputs" window. It is recommended to delete unused outputs and keep only "HTTP Push" in the list. The procedure to delete all other applications is to click on the desired ellipsis button of the application "...", and select **Delete** option. A pop-up window will ask you to confirm the operation.

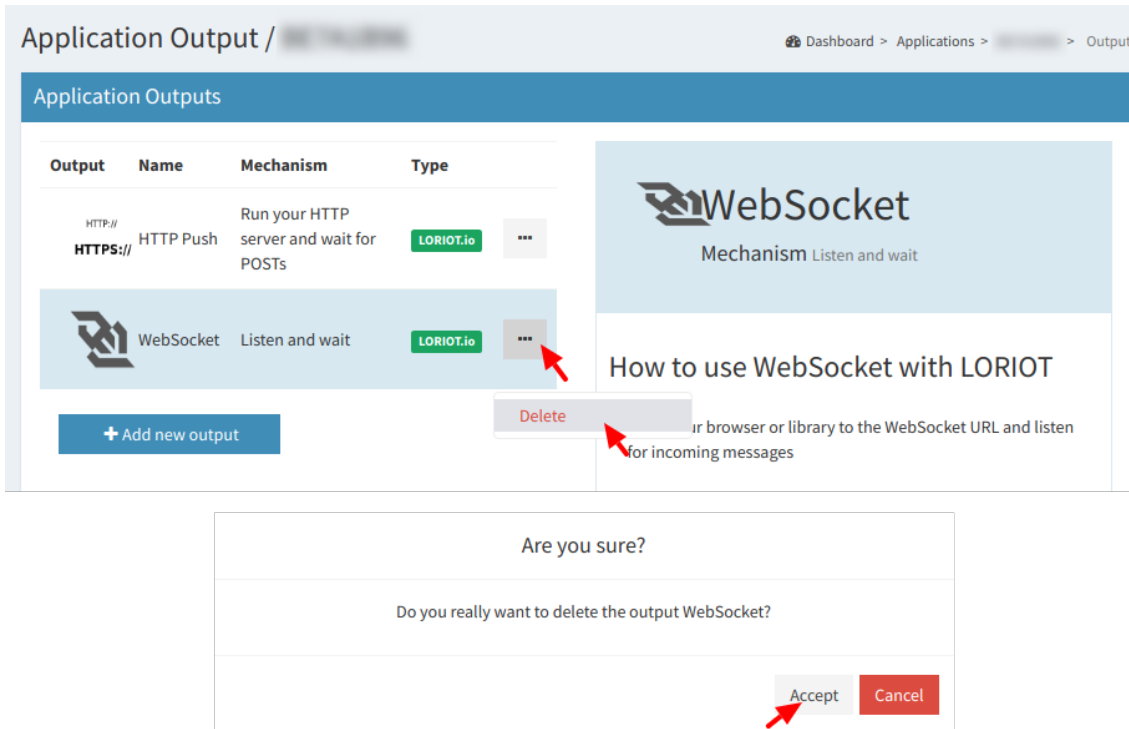

Figure : Delete unused application outputs

### 6.1.5. How to create a single device manually

Click on **"Devices"** left menu to show the device list. Click on **"Enroll new device"** button to add a new device:

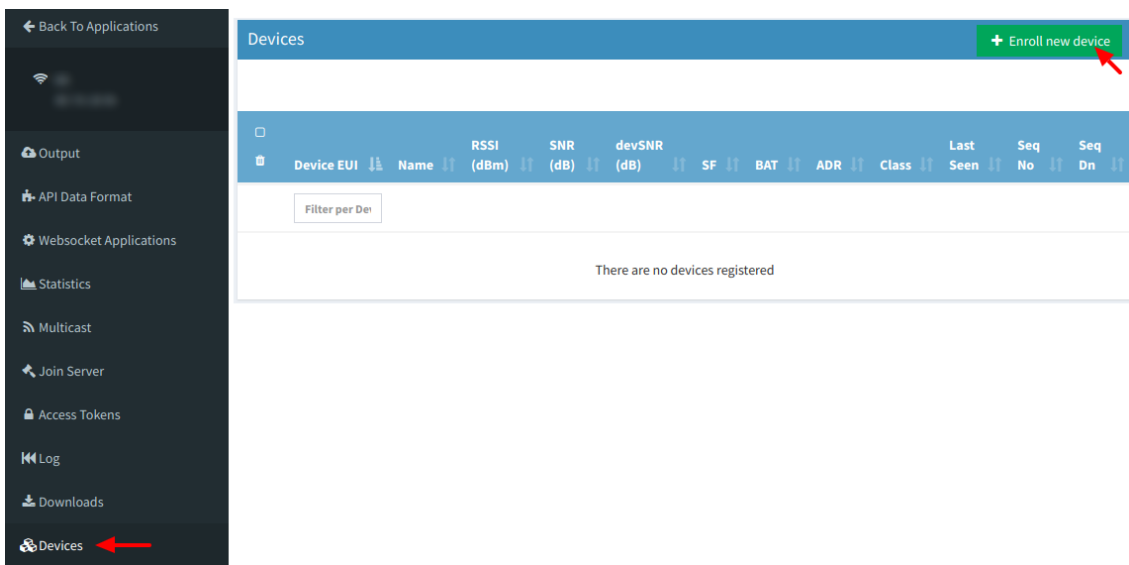

Figure : Enroll new device

A new form will be displayed in order to create the new device associated to the application. In this form it is possible to choose different enrolling processes based on OTAA or ABP. So, depending on the option chosen, it will be mandatory to insert different EUIs or keys. Please refer to “[LoRaWAN protocol and parameters](#)” to understand the all parameters involved in this form.

**Enroll a new device**

**LoRaWAN Version**

**Enrollment process**

**Device Location**

**Country**

**Address**

**ZIP Code**

**City**

**Latitude**

**Longitude**



**Device Details**

<b>Title</b>	<b>End-device address</b>	<b>Sequence number uplink</b>	<b>Sequence number downlink</b>
<input type="text"/>	<input type="text" value="DevAddr (8)"/>	<input type="text" value="FCntUp (Decim)"/>	<input type="text" value="FCntDn (Decim)"/>
<b>EUI (optional)</b>	<b>Network session key</b>		
<input type="text" value="DevEUI (16 hex digi)"/>	<input type="text" value="NWKSEY (32 hex digits)"/>		
<b>Description</b>	<b>Application session key</b>		
<input type="text"/>	<input type="text" value="APPSKEY (32 hex digits)"/>		

Create Another

**About ABP enrollment v1:**

Activation by personalization (ABP) is a method of delivering the network and application session key material by configuring it manually on every device.

The ABP static allocation of the device keys is less secure than OTAA.

Upon enrollment of your device, we will generate all the necessary keys and identifiers for you - DevAddr, NwkSKey and AppSKey. You can use this information to setup your end-device

In your device, you will need to configure the following parameters:

- DevAddr - will be generated upon completing this step
- NwkSKey - will be generated upon completing this step
- AppSKey - will be generated upon completing this step

Figure : New device form

## 6.1.6. Nodes batch provisioning in Lorient

Inside the Lorient application click on "**Bulk import**" and then click on "**Upload file**" to register several devices at a time. It asks for a CSV file which must be exported from Libelium Cloud (SCM).

Please refer to “[Libelium Cloud management](#)” section for further information on how to export this CSV file which includes all nodes OTAA credentials needed for direct batch import.

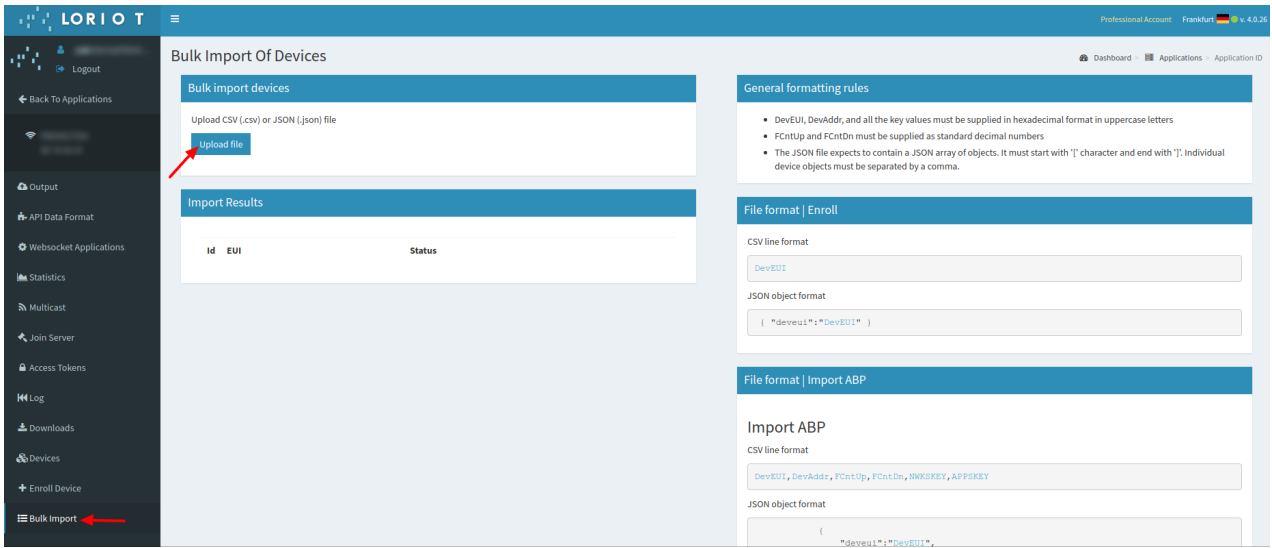

Figure : Lorient bulk import

The CSV file for 'N' devices must respect the next format:

---

```

<DevEUI_1>,<AppEUI_1>,<AppKey_1>,<Name_1>
<DevEUI_2>,<AppEUI_2>,<AppKey_2>,<Name_2>
<DevEUI_3>,<AppEUI_3>,<AppKey_3>,<Name_3>
...
<DevEUI_N>,<AppEUI_N>,<AppKey_N>,<Name_N>

```

---

## 6.2. Activity

This section explains how to route the information via Activity network server to the "Customer server" using the HTTPS protocol. Firstly, you must access into the Activity's [ThingPark portal](#) and log in. IN the main portal, you must go to "**ThingPark Application**" section and access to "**Device Manager**":

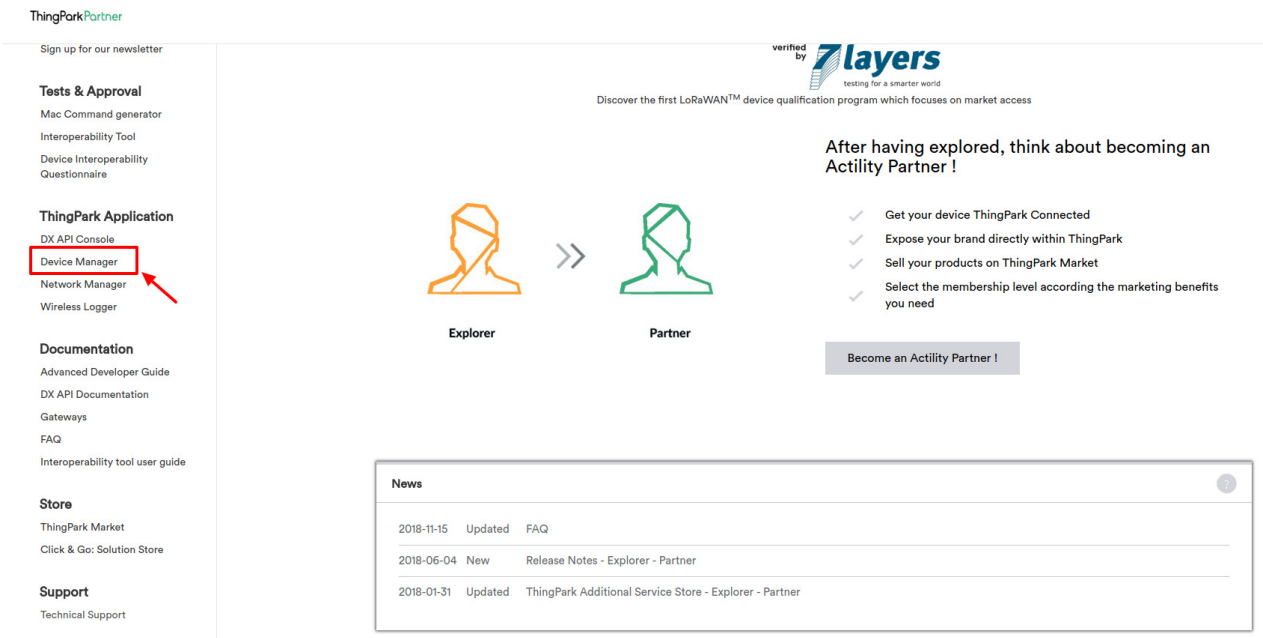

Figure : Access to "Device Manager" menu

Activity requires an "Application Server" and an "AS routing profile" in order to establish the communication with the Customer server or Libelium Cloud. These two elements are required before starting the service the first time, and will be the base to create new devices.

### 6.2.1. How to create a new Application Server

Starting from the main ThingPark Device Manager window, you shall create a new "Application Server" by clicking on "**Application Servers**":



Figure : Device Manager menu

The first section allows you to create a new "Application Server". Then the second section shows a list of all "Application servers" created. Click on the "**Create**" button in the first section to create a new "Application Server":

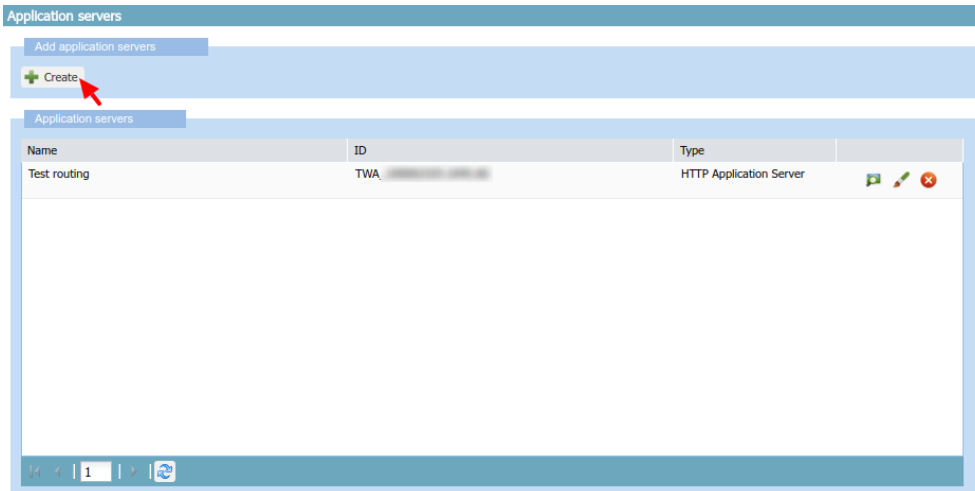

Figure : Application servers menu

In "Name" field define your Application server name. In "Type" field, you must select "HTTP Application Server". Finally, click on the **"Create"** button to continue:

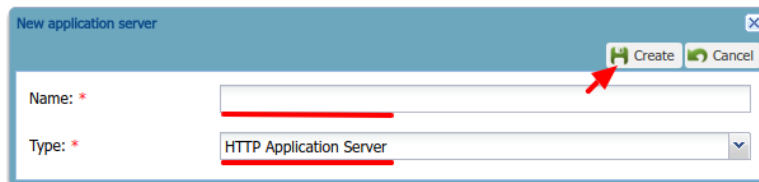

Figure : Application server name

A new window appears, where the name is copied from the previous pop-up. In the "Content Type" field you must select **"JSON"**. Then click on the **"Add"** button in "Add a route" section to create the link to the callback server installed:

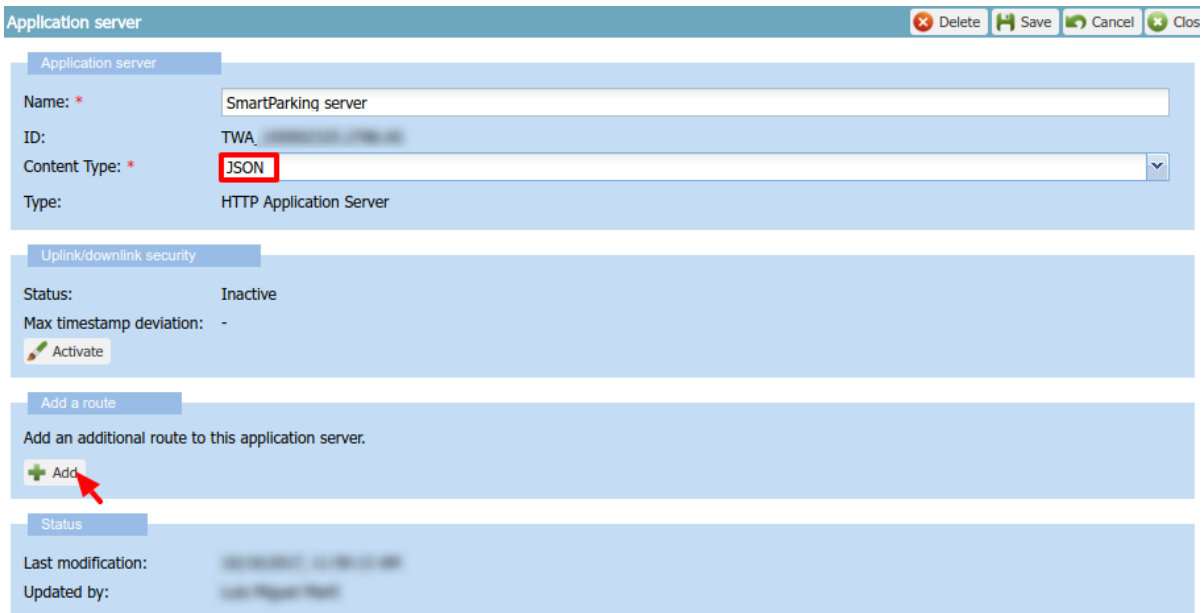

Figure : Application server form

A "Route" section will be generated with a new form to be completed. Just click the **"Add"** button to proceed:

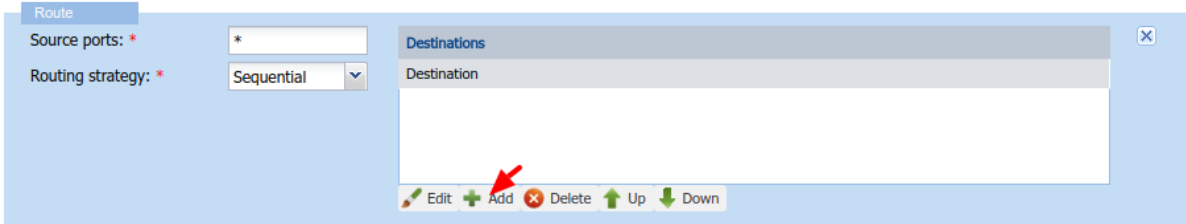

Figure : Route form

A new pop-up appears. In the "Destination" field, you must enter the URL of the server where the data is going to be sent. Click on the **"Add"** button to save the information:

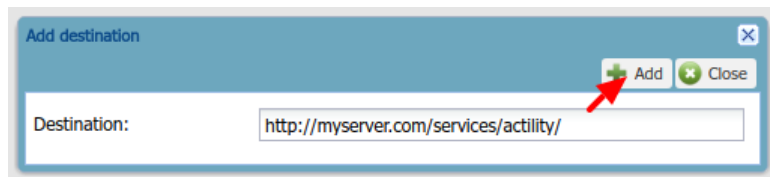

Figure : Destination form

Navigate back to the Application server form, click on **"Save"** in order to create the "Application server".

## 6.2.2. How to create a new AS routing profile

The Application Server (AS) routing profile defines how a previously created "Application server" will behave. In order to create a new "AS routing profile" in the Device Manager, click on **"AS routing profiles"** button on the left sidebar menu:



Figure : Destination form

Then you must click on the **"Add"** button in the first section. Below, in the second section, a list with all existing "AS routing profiles" will be displayed:



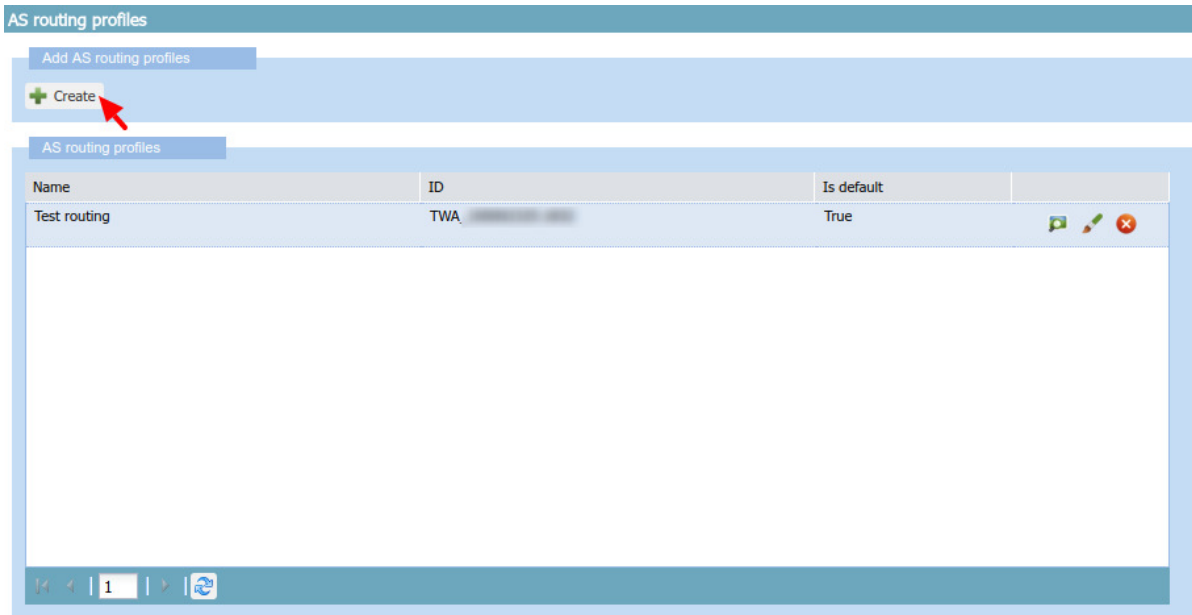

Figure : AS Routing profiles

In the "Name" field write the name of the AS routing profile. In the "Type" field, select LoRaWAN. Then click on the **"Create"** button to continue the process:

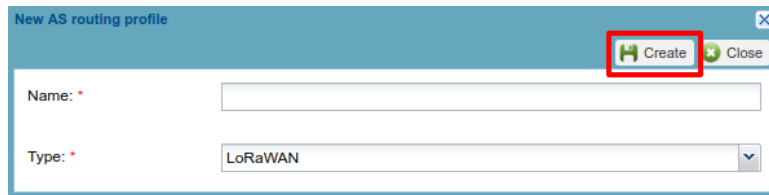

Figure : AS Routing profile name

In the new window, you can read the "AS routing profile ID" which will be needed for batch import. Besides, mark the check "Is default" and click the **"Add button"**:

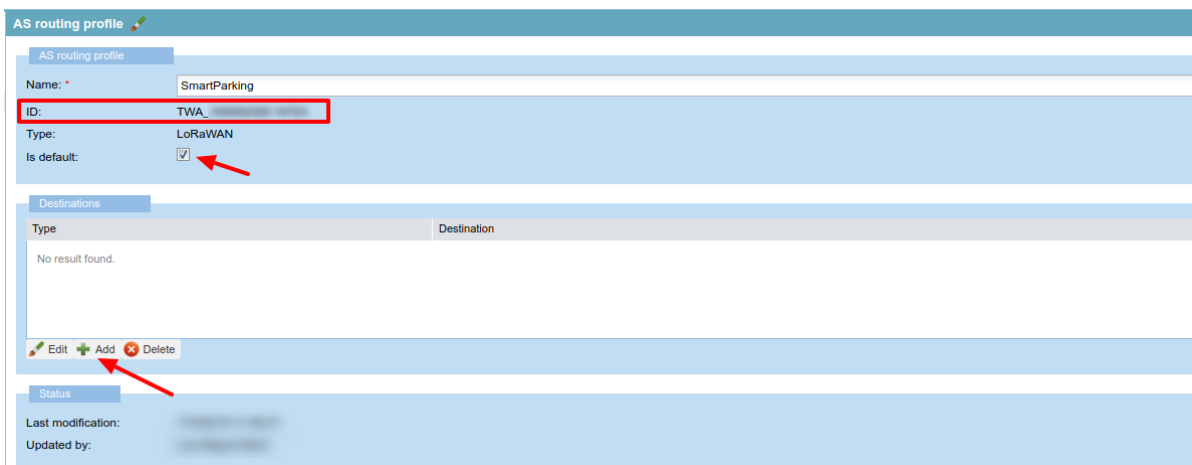

Figure : AS Routing profile route

A new pop-up will appear with two parameters to be completed. "Type" is the kind of the application for our destination, **"Local application server"** must be selected. In "Destination" drop-down field, all available Application servers will be displayed. So, the correct "Application server" previously created must be selected:

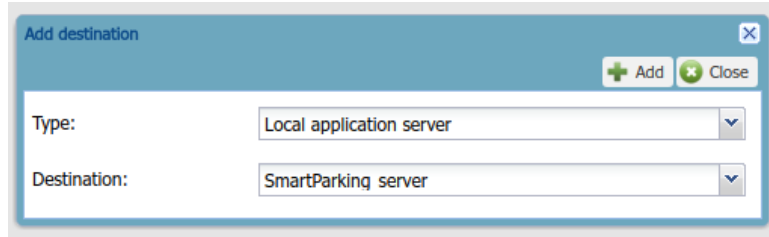

Figure : Add the created Application server as "destination" for the routing profile

Navigate back to the AS routing profile form, click on **"Save"** in order to create it. This process should be completed just once. From this moment, customers can add devices to the service.

### 6.2.3. How to create new devices manually

Once created the "Application server" and "AS routing profile", you can create new devices.

In the main ThingPark menu, click on **"Devices"** option . Then click on the **"Create"** button:

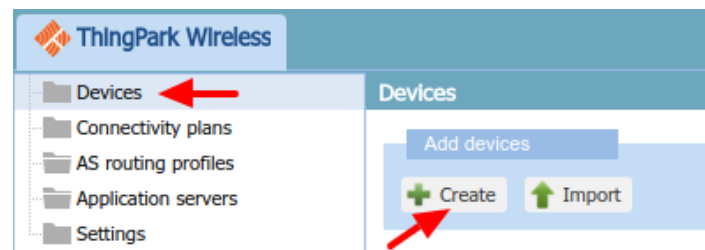

Figure : Create new devices

A new form will be displayed in order to define the new device's parameters:

#### Administrative data

- Device name: Name to identify the device
- Marker: Icon to identify the device on the map list
- Administrative info: Relevant information of the device
- Administrative location: Location of the device
- Motion indicator: List with several options

#### Device identification

- Manufacturer: Select "Generic".
- Model: Select the corresponding region:
  - LoRaWAN EU863-870: LORA/GenericA.1.0.2a\_ETSI\_Rx2-SF12
  - LoRaWAN US902-928: LORA/GenericA.1.0.2a\_FCC\_Rx2-SF12
  - LoRaWAN IN865-867: LORA/GenericA.1revB\_IN865\_Rx2-SF12
  - LoRaWAN AU915-928: LORA/GenericA.1revB\_AU915\_Rx2-SF12
  - LoRaWAN AS923: LORA/GenericA.1\_AS923\_Rx2-SF10
- Device activation: Select "Over The Air Activation (OTAA)" if default parameters are used. ABP is the other option.
- DevEUI: Device EUI, globally unique IEEE EUI-64 address.
- AppEUI: Device Application identifier (mandatory for OTAA).
- Key format: Should be "Clear text" for non-encrypted key format.

- AppKey: 16-byte Application Key (mandatory for OTAA).

### Network parameters

- Connectivity plan: Select a Connectivity plan on the drop-down menu.
- DevAddr: Select "Allocated by the network server".

### Application layer handling

- Application server routing profile: Select the "Application server" created before.

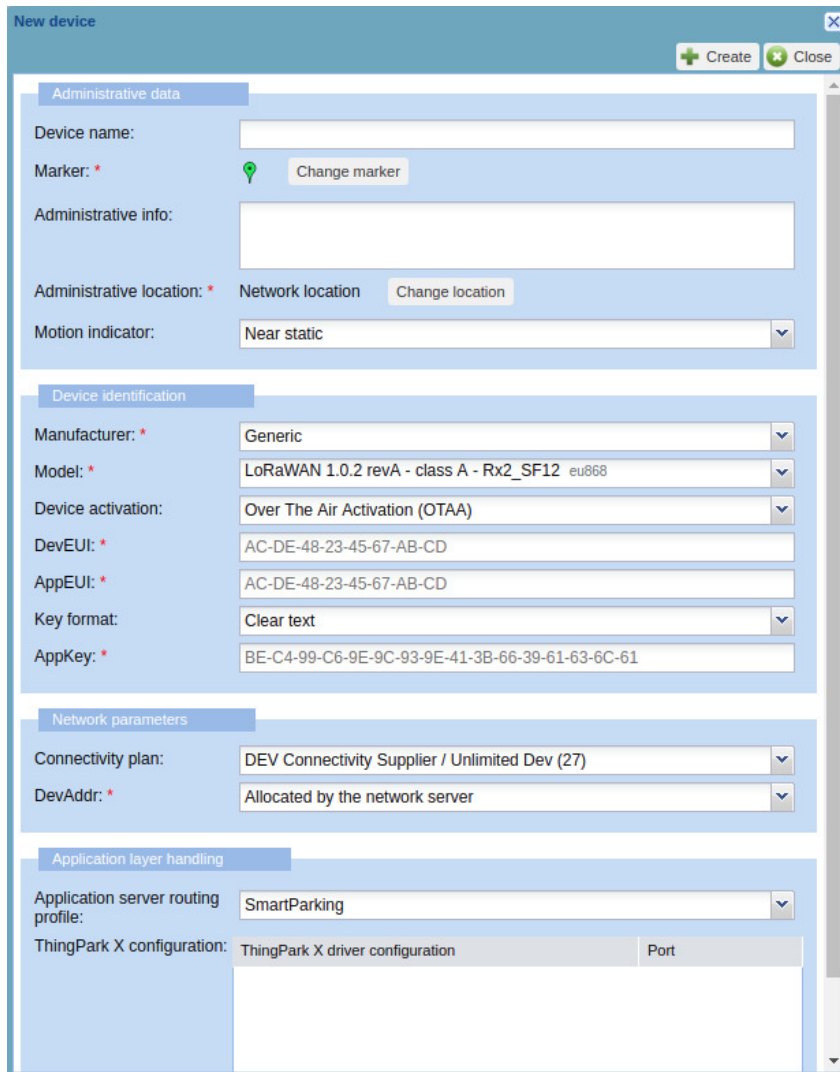

The screenshot shows a 'New device' configuration window with the following fields and values:

- Administrative data:**
  - Device name: (empty text field)
  - Marker: \* (green location pin icon, 'Change marker' button)
  - Administrative info: (empty text field)
  - Administrative location: \* (Network location, 'Change location' button)
  - Motion indicator: (Near static dropdown)
- Device identification:**
  - Manufacturer: \* (Generic dropdown)
  - Model: \* (LoRaWAN 1.0.2 revA - class A - Rx2\_SF12 eu868 dropdown)
  - Device activation: (Over The Air Activation (OTAA) dropdown)
  - DevEUI: \* (AC-DE-48-23-45-67-AB-CD text field)
  - AppEUI: \* (AC-DE-48-23-45-67-AB-CD text field)
  - Key format: (Clear text dropdown)
  - AppKey: \* (BE-C4-99-C6-9E-9C-93-9E-41-3B-66-39-61-63-6C-61 text field)
- Network parameters:**
  - Connectivity plan: (DEV Connectivity Supplier / Unlimited Dev (27) dropdown)
  - DevAddr: \* (Allocated by the network server dropdown)
- Application layer handling:**
  - Application server routing profile: (SmartParking dropdown)
  - ThingPark X configuration: (Table with columns 'ThingPark X driver configuration' and 'Port')

Figure : Enter all device's parameters

Finally click on the **"Create"** button in order to save the information of the device.

## 6.2.4. Nodes batch provisioning in Activity

It is possible to register several nodes at a time using the **"Import"** button:

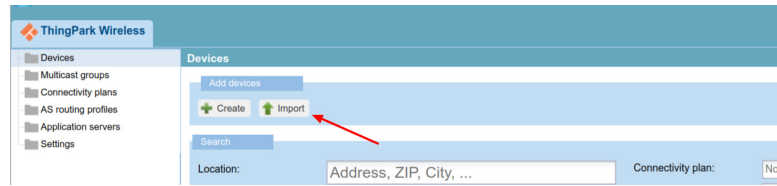

Figure : Import devices

A new window is displayed in order to import a CSV file with all devices to be imported:

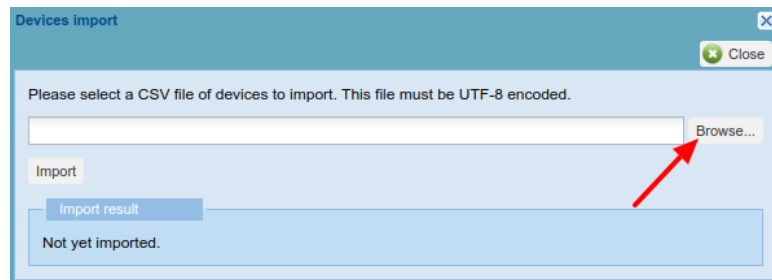

Figure : Import CSV file

Regarding the CSV file format, you must start from the exported CSV file from Libelium Cloud (SCM). Please refer to "Libelium Cloud management" section for further information on how to export this CSV file which includes all nodes OTAA credentials needed for direct batch import. Then, you must keep in mind that Actility needs more information to be included in that CSV file. The CSV to be imported must follow the next format (15 columns). The CSV file for 'N' devices must respect the next format:

---

```

CREATE_OTAA,<DevEUI_1>,<DevProfile>,<AppEUI_1>,<AppKey_1>,<AS_profile_ID>,<ConnectivityPlan>,<name>,,,,,
CREATE_OTAA,<DevEUI_2>,<DevProfile>,<AppEUI_2>,<AppKey_2>,<AS_profile_ID>,<ConnectivityPlan>,<name>,,,,,
CREATE_OTAA,<DevEUI_3>,<DevProfile>,<AppEUI_3>,<AppKey_3>,<AS_profile_ID>,<ConnectivityPlan>,<name>,,,,,
...
CREATE_OTAA,<DevEUI_N>,<DevProfile>,<AppEUI_N>,<AppKey_N>,<AS_profile_ID>,<ConnectivityPlan>,<name>,,,,,
  
```

---

Where:

- **CREATE\_OTAA**: Should always be the same in order to import the devices using OTAA join mode.
- **<DevEUI>**: This is the Device EUI exported from Libelium SCM CSV file. Should not be changed.
- **<DevProfile>**: This field is related to the LoRaWAN region of the node. Possibilities depending on the version:
  - LoRaWAN EU863-870: LORA/GenericA.1.0.2a\_ETSI\_Rx2-SF12
  - LoRaWAN US902-928: LORA/GenericA.1.0.2a\_FCC\_Rx2-SF12
  - LoRaWAN IN865-867: LORA/GenericA.1revB\_IN865\_Rx2-SF12
  - LoRaWAN AU915-928: LORA/GenericA.1revB\_AU915\_Rx2-SF12
  - LoRaWAN AS923: LORA/GenericA.1\_AS923\_Rx2-SF10
- **<AppEUI>**: This is the Application EUI exported from Libelium SCM CSV file. Should not be changed.
- **<AppKey>**: This is the Application Key exported from Libelium SCM CSV file. Should not be changed.
- **<AS\_profile\_ID>**: This is Actility's "AS routing profile ID" which belongs to each customer's account. It can be read from the profile when it is first created.
- **<ConnectivityPlan>**: This must be set as "dev-cs/testing".
- **<name>**: Name of each device (optional).

Example for some Smart Parking EU nodes (LoRaWAN EU863-870). Let's assume TWA\_123 was the "AS routing profile ID" given by Actility for our application:

```
CREATE_OTAA,<EUI1>,,LORA/GenericA.1.0.2a_ETSI_Rx2-SF12,<AppEUI1>,<AppKey1>,,dev-cs/testing,TWA_123,,Node1,,,,,  
CREATE_OTAA,<EUI2>,,LORA/GenericA.1.0.2a_ETSI_Rx2-SF12,<AppEUI2>,<AppKey2>,,dev-cs/testing,TWA_123,,Node2,,,,,  
CREATE_OTAA,<EUI3>,,LORA/GenericA.1.0.2a_ETSI_Rx2-SF12,<AppEUI3>,<AppKey3>,,dev-cs/testing,TWA_123,,Node3,,,,,  
CREATE_OTAA,<EUI4>,,LORA/GenericA.1.0.2a_ETSI_Rx2-SF12,<AppEUI4>,<AppKey4>,,dev-cs/testing,TWA_123,,Node4,,,,,  
CREATE_OTAA,<EUI5>,,LORA/GenericA.1.0.2a_ETSI_Rx2-SF12,<AppEUI5>,<AppKey5>,,dev-cs/testing,TWA_123,,Node5,,,,,
```

---

## 7. Customer Server

In order to communicate with any LoRaWAN Network Server you need a web application up and running. The web application will receive LoRaWAN requests via POST/GET requests depending on the server. Libelium provides the source files of a simple web application called Customer Server, created to be deployed on your server.

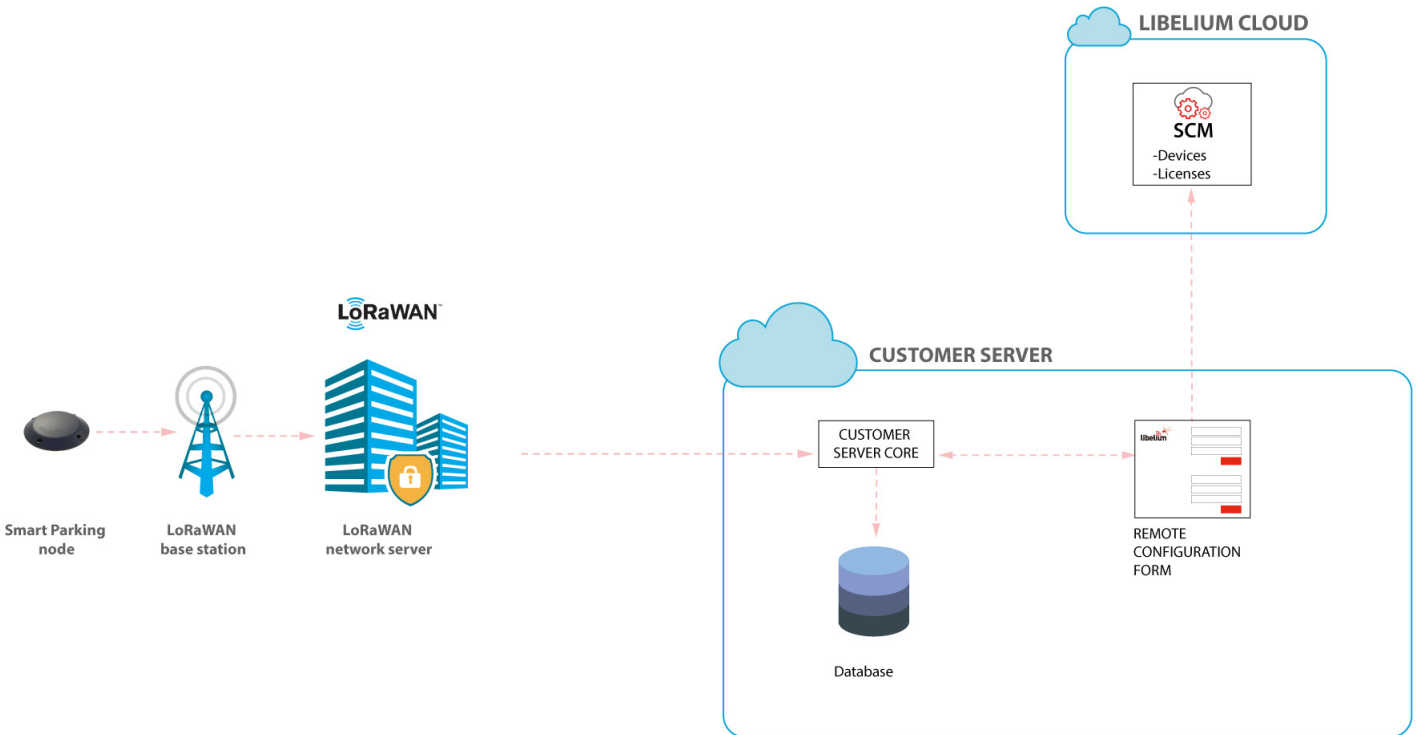

Figure : Customer Server

The Customer Server is composed of 2 parts:

- the Remote Configuration Form: it manages the configuration values of the Smart Parking nodes)
- the Customer Server Core: it deals with the LoRaWAN Network Server requests, sending back a response when needed.

If the user wants to use the Remote Configuration Form, all Smart Parking nodes must be registered on the Libelium Cloud. There is no need of additional licenses.

The Customer Server must be deployed on your own server. Besides, the LoRaWAN Network Server must be configured with the complete URL containing your server domain name or IP. The context should point to the web application deployment path.

**Note:** Customers can ask for this source code to our Sales Team ([sales@libelium.com](mailto:sales@libelium.com)) after buying the nodes.

## 7.1. Installation

There are 2 ways to install the Customer Server: installing it on your own server with Docker or installing it manually on your own server.

Assigning a public IP and a registered domain name to the server is recommended to ease the task of configuring LoRaWAN Network Server to send HTTP/HTTPS requests to this server. It is also a good practice to implement existing security policies (user credentials, SSL, firewall, and tools to avoid DoS attacks) for servers with open ports to Internet.

### 7.1.1. Docker

If you want to use Docker, you must install Docker and Docker Compose on your server. In order to install these tools, you should follow the instructions from the official documentation by Docker:

- Docker installation instructions: <https://docs.docker.com/install/>
- Docker Compose installation instructions: <https://docs.docker.com/compose/install/>

You can also hire online services which offer a virtual server with Docker already installed on it.

### 7.1.2. Server

The minimum requirements for the server are:

- Apache web server  $\geq 2.4$
- PHP  $\geq 7.1.3$
- Database: MySQL or PostgreSQL
- ionCube Loader

An Apache webserver with PHP support and a database must be configured on your server. Those are the minimum requirements to deploy the Customer Server web application.

Even if you are not using Docker, you can use 2 files as a reference to install all the dependencies of the project. These files are Dockerfile and docker-compose.yml, and can be found on the source code that the Sales Team provides (bin/ci/smart\_parking).

Info and tutorials about installation of minimum requirements of your server:

- Ubuntu: <https://help.ubuntu.com/community/ApacheMySQLPHP>
- Windows: <http://www.ampsoft.net/webdesign-l/how-to-install-apache-php-mysql.html>
- Mac: <http://jason.pureconcepts.net/2012/10/install-apache-php-mysql-mac-os-x/>
- ionCube Loader: <http://www.ioncube.com/loaders.php>

## 7.2. Deploying

### 7.2.1. Docker

- Step 1: Extract on your server the zip file provided by Libelium containing the Customer Server application source files.
- Step 2: Go to the folder bin/ci/smart\_parking.
- Step 3: You should modify the files Dockerfile and docker-compose.yml that we provide in order to make sure that the security required for your project is matched.



- **Database:** We provide a file with the structure for the database, you can change the name of the main table and also use it to add any additional tables you may need, the file is located on:

---

```
bin/ci/smart_parking/docker-entrypoint-initdb.d/init.sql
```

---

This file will be executed one time when the database container is created and it should be added to the docker group.

- File structure: The application files should be placed in the “www-data” group from the web container. You can map a host user to www-data by UID as it is commented on the Dockerfile or you can assign the files to the correct UID (33 by default).
- Step 4: Execute “docker-compose up” to launch the project (the 1st time, it may take some time to execute).
- Step 5: You can check if the installation is completed navigating to “http://MACHINE\_IP:7000”: you should see the Remote Configuration Form login screen.

## 7.2.2. Server

- Step 1: Extract on your server the zip file provided by Libelium containing the Customer Server application source files.
- Step 2: Check the right owner/group and permissions of all the files extracted, usually using www-data group is default in Ubuntu environment.
- Step 3: Check the permissions of all folders and files, usually using 0770 for directories and 0660 for files is default in Ubuntu environment.
- Step 4: Configure in your server the context of the callback server application with the path where the source files were extracted.

Copy and paste the following text as content of the file “my\_server.conf” file located on “/etc/apache2/sites-available” (replace paths to match your server deployment locations):

---

```
<VirtualHost *:80>
    ServerAdmin webmaster@localhost
    ServerName my_server.com
    ServerAlias my_server.com

    DirectoryIndex index.html index.php
    DocumentRoot /path/zip/extracted

    ErrorLog ${APACHE_LOG_DIR}/error.log
    CustomLog ${APACHE_LOG_DIR}/access.log combined

    <Directory /path/zip/extracted>
        Options Indexes FollowSymLinks
        AllowOverride All
        Require all granted
    </Directory>
</VirtualHost>
```

---

## 7.3. Configuring the application

Initialize the nodes storage:

---

```
cd src/storage/app/parking
cp nodes.example.json nodes.json
```

---

Copy "src/.env.example" to "src/.env" and edit the file:

---

```
APP_NAME='Smart Parking v2 - Customer Server'
APP_ENV=local
APP_DEBUG=false
APP_URL=http://localhost
APP_TIMEZONE=UTC

# Set to true to use the database:
USE_DB=false

# This data should match the data on the file docker-compose.yml:
DB_CONNECTION=mysql
DB_HOST=db
DB_PORT=7001
DB_DATABASE=LoriotDB
DB_USERNAME=user
DB_PASSWORD=password

CACHE_DRIVER=file

# It is mandatory to set a service (Loriot|Actility):
SERVICE=''

# If you want to use Loriot you must fill these fields:
LORIOT_URI=''
LORIOT_APP_ID=''
LORIOT_TOKEN=''

LORIOT_API_KEY=''

# If you want to use Actility you must fill these fields:
ACTILITY_URI=''
ACTILITY_TOKEN=''
```

---

If you want to use either Actility or Loriot you must specify which one you want to use; you must fill all the configuration fields.

### 7.3.1. How to configure Loriot

Write "Loriot" in the "SERVICE" field:

---

```
SERVICE='Loriot'
```

---

For the remaining fields:

---

```
LORIOT_URI='https://serverID.loriot.io/1/'
```

---

“serverId” is the Lloriot server from which your Lloriot application is served, you can find it on the URL of your Lloriot account.

---

```
LORIOT_APP_ID='appId'
```

---

“appId” is the ID of your Lloriot application. You can find it on the “Network application” section of your Lloriot account:

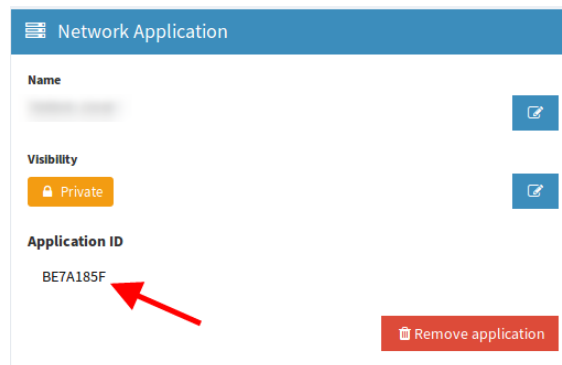

Figure : Lloriot application ID

---

```
LORIOT_TOKEN='loriotToken'
```

---

“loriotToken” is the ID of your Lloriot application. You can find it on the “Application tokens” section of your Lloriot account:

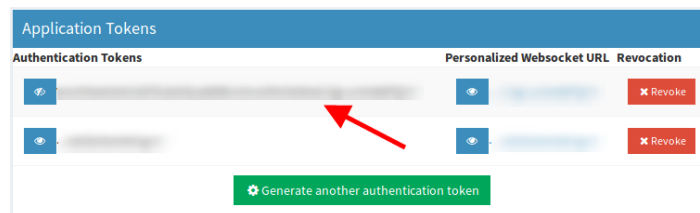

Figure : Lloriot token

---

```
LORIOT_API_KEY='loriotApiKey'
```

---

“loriotApiKey” is a key you can obtain on the “Account” section of the Lloriot panel:

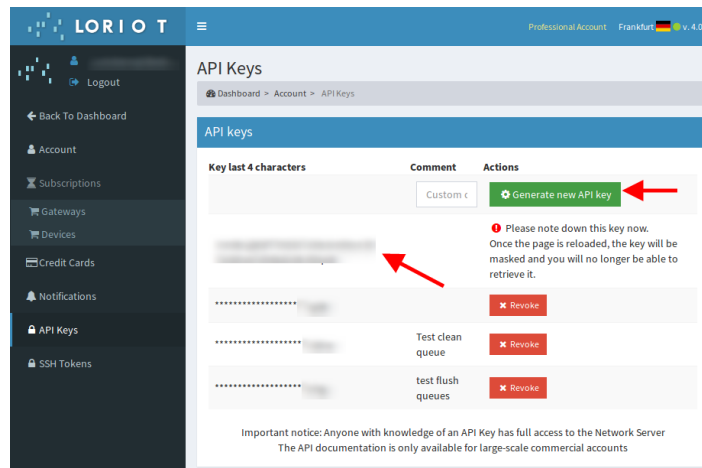

Figure : Loriot API key

## 7.3.2. How to configure Actility

Write "Actility" in the "SERVICE" field:

---

`SERVICE='Actility'`

---

And the remaining field:

---

`ACTILITY_URI='actilityURI'`

---

"actilityURI" is the downlink URL that Actility provides to send information from the server to the node. This URL is the address of the primary Actility LRC cluster.

## 7.4. Making the server accessible from anywhere

### 7.4.1. Mandatory for Loriot and Actility platforms

Optimal deployment includes a server name pointing to a public and static IP. Using dynamic DNS could be done with services like no-ip which has a free package (see <http://www.noip.com/>). No-ip has also a client application responsible for updating any IP address changes in the background (for more information go to <http://www.noip.com/download>).

Finally, the URL to be configured in the LoRaWAN Network Server must be created concatenating the server name and the paths:

Loriot: [https://my\\_server.com/api/parking/v2/services/loriot](https://my_server.com/api/parking/v2/services/loriot)

Actility: [https://my\\_server.com/api/parking/v2/services/actility](https://my_server.com/api/parking/v2/services/actility)

## 7.5. Remote Configuration Form

The Remote Configuration Form is a web application which permits to update some node parameters (sensor and timing parameters). This is done thanks to the OTA-S (Over-The-Air-Setup) functionality. The update is done remotely via LoRaWAN downlink packets. LoRaWAN parameters cannot be updated with the Remote Configuration

Form.

For accessing the Remote Configuration Form, log in with your user and password from your Libelium Cloud account. Enter your credentials and press "Login".

#### LOGIN INTO THE LIBELIUM CLOUD

User:

systems@libelium.com

Password:

●●●●●●●●

Login

Figure : User login

Select one or several devices on the drop-down menu. Each device is identified by their unique LoRaWAN EUI. The nodes displayed in the drop-down menu correspond to the nodes you have claimed for on your Libelium Cloud account. You can also deselect previously selected nodes using the cross icon.

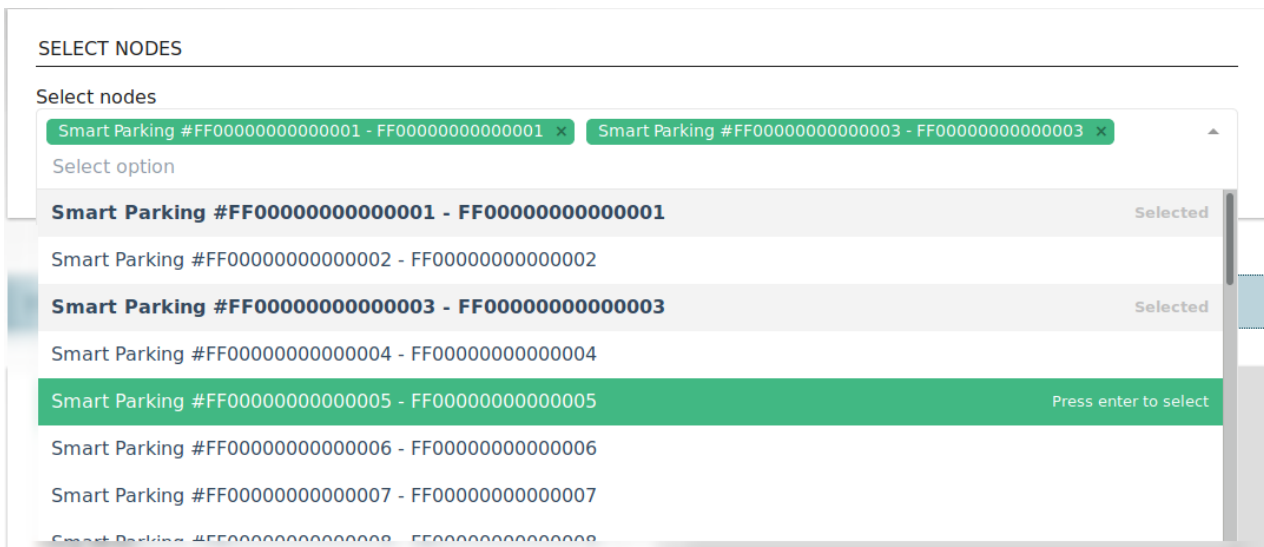

The screenshot shows a web interface titled "SELECT NODES". Below the title is a "Select nodes" section with a dropdown menu. The dropdown menu is open, showing a list of nodes. Each node entry consists of a text label and a "Selected" status indicator on the right. The text labels are "Smart Parking #FF00000000000001 - FF00000000000001", "Smart Parking #FF00000000000002 - FF00000000000002", "Smart Parking #FF00000000000003 - FF00000000000003", "Smart Parking #FF00000000000004 - FF00000000000004", "Smart Parking #FF00000000000005 - FF00000000000005", "Smart Parking #FF00000000000006 - FF00000000000006", "Smart Parking #FF00000000000007 - FF00000000000007", and "Smart Parking #FF00000000000008 - FF00000000000008". The first, third, and fifth entries are highlighted in green and have a "Selected" status. The second, fourth, sixth, seventh, and eighth entries are highlighted in light blue and have a "Selected" status. The fifth entry also has a "Press enter to select" status. There are small 'x' icons next to the first and third entries, indicating they can be deselected.

Figure : Smart Parking node selection

Once a node is selected, its current configuration is displayed and you can modify it. For further information of the node parameters, please refer to the chapter "[Smart Parking node](#)".

**TIME SETTINGS**

Sleep time (minutes)  
1 min

Keep-Alive  
2h

**NIGHT MODE**

Enabled

Duration  
6h

Start Hour  
0h

Sleep Time  
5 minutes

Keep-Alive  
4h

**RADAR SENSOR CONFIGURATION**

Radar range start  
20

Radar range length  
60

Radar threshold  
25

**RESET**

Reset

[Save configuration](#)

Figure : Smart Parking node configuration

Once you have configured the node or nodes, press the “Save configuration” button. A message is shown indicating that a downlink frame with the node’s configuration has been enqueued on the downlink queue of the LoRaWAN Network Server. Therefore, the node will receive a downlink frame with the new configuration in response to the next Info frame or Keep Alive frame.

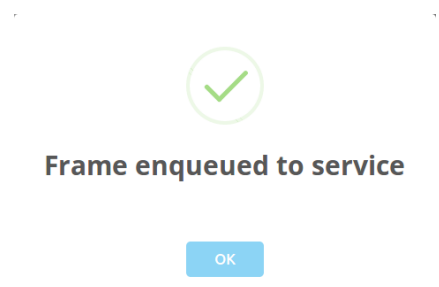

Figure : Frame enqueued for processing

So the Remote Configuration Form application allows the user to update some node parameters, just as the Smart Devices App does. However, using the Smart Devices App requires physical access to the Smart Parking node: the node must be plugged to a computer with a USB cable.

**Note:** The Remote Configuration Form does not permit to update any LoRaWAN parameter. The Smart Devices App should be used instead.

## 7.6. Customer Server Core

The Customer Server Core deals with the LoRaWAN Network Server requests delivering the proper replies if needed. When it receives a new uplink frame, it parses its data to identify all fields and perform adequate operations. By default, the source code is prepared to insert the parsed data into a MySQL database.

Regarding the frame type, if a "Start Frame 1" or "RTC Update Request" frames are received, then a new downlink frame is immediately enqueued into the LoRaWAN Network Server with the proper answer.

On the other hand, when the Remote Configuration Form is managed in order to update node parameters, a downlink frame is sent to the LoRaWAN Network Server with the new values.

For further information about the different frame types please refer to the "[Frame types](#)" section.

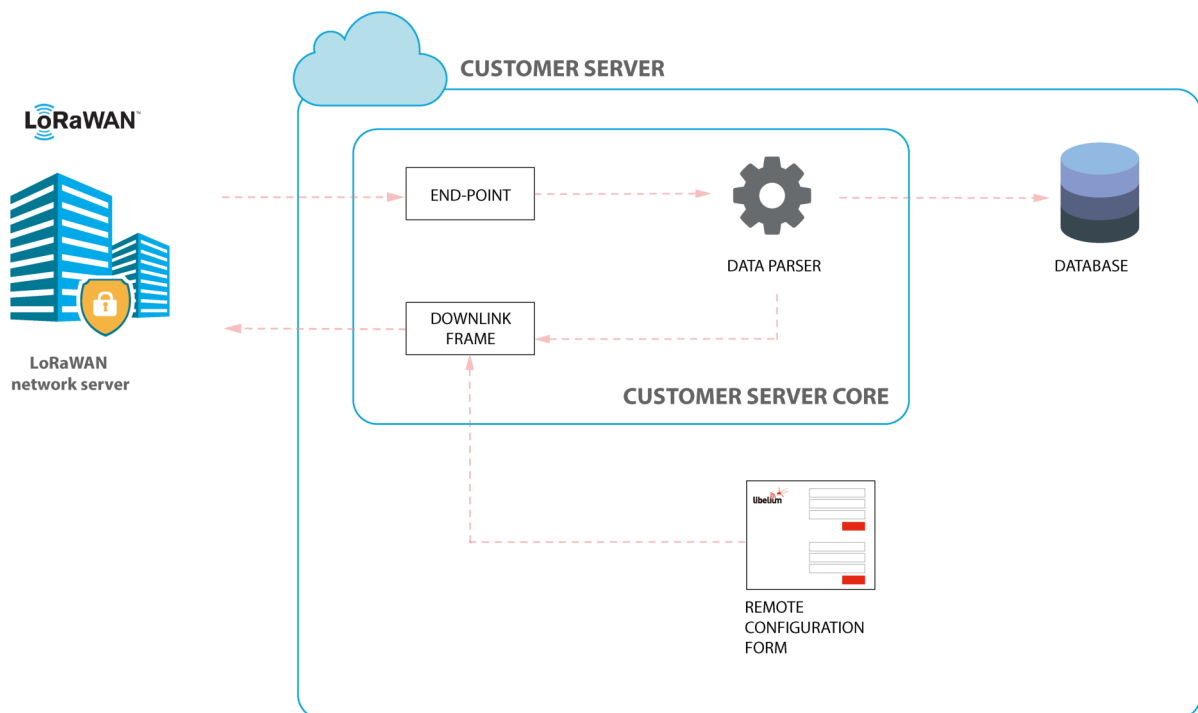

Figure : Customer Server Core

### 7.6.1. End-point

Once you have installed and configured the Customer Server, the system will be prepared to listen to LoRaWAN requests. The end-point will vary depending on the configured LoRaWAN service. By default, the source code is prepared for both Lorient and Activity network servers.

### 7.6.2. Data Parser

The Data Parser will unpack the payload data sent by the node before the insertion on the database. It will also prepare the proper response to the LoRaWAN Network Server if needed.

### 7.6.3. Database

The Customer Server Core inserts data into a MySQL database upon uplink frames arrival. The uplink frames are parsed by the Data Parser and the source code is capable of performing smart database insertions by accessing to previously stored information. For example, a loss in the sequence number is calculated by reading the previous sequence number insertion. Besides, the node time settings (Sleep time, Keep Alive time, etc) are stored since the "Start frame 1" and "Start frame 2" are received so it is possible to access to the current node configuration any time.

The structure of the database provided is:

Database Field	Field updated by	Description
<b>LW_EUI</b>	All uplink frames	The node's unique LoRaWAN EUI.
<b>LW_ts</b>	All uplink frames	The uplink frame timestamp.
<b>LW_up_counter</b>	All uplink frames	The LoRaWAN protocol uplink counter. This field belongs to the link level. Range: from 0 to 4294967295.
<b>LW_port</b>	All uplink frames	The LoRaWAN port used to send the data. Range: from 1 to 223.
<b>LW_rssi</b>	All uplink frames	The uplink "Received Signal Strength Indication" (dBm).
<b>LW_dr</b>	All uplink frames	The uplink frame datarate.
<b>LW_uplink</b>	All uplink frames	The uplink frame contents in HEX digits.
<b>LW_downlink</b>	All uplink frames	The enqueued downlink frame in response to the uplink received. The contents in HEX digits. Normally this field is empty.
<b>frame_type_uplink</b>	All uplink frames	The frame type of the received uplink frame.
<b>parking_slot_status</b>	Info, Keep-alive, RTC update	The status of the parking lot (0: free; 1: occupied).
<b>battery_state</b>	All uplink frames	The battery state of the node (0: OK; 1: warning).
<b>recalibration</b>	All uplink frames	Flag to indicate sensor recalibration since last uplink (0: no; 1: yes).
<b>sequence_number</b>	All uplink frames	The application level sequence number. This field belongs to the frame contents. Range: from 0 to 255.
<b>lost_up_counter (*)</b>	All uplink frames	Field to indicate the loss of a LoRaWAN protocol sequence number.
<b>lost_seq (*)</b>	All uplink frames	Field to indicate the loss of an application sequence number.
<b>sensor_error</b>	Info, Keep-alive, RTC update	Field to indicate an error in sensor management (0: no error).
<b>temperature</b>	Info, Keep-alive, RTC update	The temperature value (Celsius degrees).
<b>time_hh</b>	Info, Keep-alive, RTC update	The node's RTC timestamp (hours field).
<b>time_mm</b>	Info, Keep-alive, RTC update	The node's RTC timestamp (minutes field).
<b>distance</b>	Info, Keep-alive, RTC update	The distance to an object provided by the sensor reading (mm units).
<b>amplitude</b>	Info, Keep-alive, RTC update	The amplitude of the object reflection provided by the sensor reading (no units).
<b>n_reflections</b>	Info	Number of reflections in sensor reading. The first reflection (most important one) is related to amplitude and distance values.



<b>battery</b>	Keep-alive, RTC update	The battery level read by the node (mV units).
<b>radar_threshold</b>	Start frame 1	The threshold configured to the radar sensor.
<b>radar_range_start</b>	Start frame 1	The starting range configured to the radar sensor (mm units).
<b>radar_range_length</b>	Start frame 1	The length of range configured to the radar sensor (mm units).
<b>firmware_version</b>	Start frame 1	The number related to firmware version.
<b>sleep_time_minutes</b>	Start frame 2	Time settings related to sleep time minutes field.
<b>sleep_time_seconds</b>	Start frame 2	Time settings related to sleep time seconds field.
<b>keep_alive</b>	Start frame 2	Time settings related to Keep-alive time field (hours field except for 0.5h which is equal to zero).
<b>nm</b>	Start frame 2	Field to indicate if night-mode is active (0: disabled; 1: enabled).
<b>nm_start_hour</b>	Start frame 2	Field to indicate when night-mode starts (hours field).
<b>nm_duration</b>	Start frame 2	Field to indicate night-mode duration (hours field).
<b>nm_sleep_time</b>	Start frame 2	Field to indicate night-mode sleep time (minutes field).
<b>nm_keep_alive</b>	Start frame 2	Field to indicate night-mode Keep-alive time (hours field).

(\*) Fields calculated by the Data Parser by accessing to previous database insertions.

For further information about the fields please refer to the “[Frame types](#)” chapter.

The next figure shows a fragment of the table on the database where data was inserted for a specific LoRaWAN EUI:

id	LW_EUI	LW_ts	LW_up_counter	LW_port	LW_rssi	LW_dr	LW_uplink	LW_downlink	frame_type_uplink	parking_slot_status	battery_state	recalibration	sequence_number	sensor_error	temperature
24601	0004A30B00288390	2019-04-30 08:27:07	550	3	-89	SF10 BW125 4/5	8126000b081b01804090d4		1	1	0	0	38	0	11
24589	0004A30B00288390	2019-04-30 07:57:05	549	3	-88	SF10 BW125 4/5	8125000a073801833f68d4		1	1	0	0	37	0	10
24572	0004A30B00288390	2019-04-30 07:27:02	548	3	-91	SF10 BW125 4/5	8124000b071a01cd4130d4		1	1	0	0	36	0	11
24561	0004A30B00288390	2019-04-30 06:56:59	547	3	-90	SF10 BW125 4/5	8123000a0638018541b8d4		1	1	0	0	35	0	10
24548	0004A30B00288390	2019-04-30 06:26:57	546	3	-97	SF10 BW125 4/5	80220009061a00e53ec005		0	1	0	0	34	0	9
24541	0004A30B00288390	2019-04-30 06:02:57	545	3	-71	SF10 BW125 4/5	0121000906020000000d1		1	0	0	0	33	0	9
24523	0004A30B00288390	2019-04-30 05:32:54	544	3	-79	SF10 BW125 4/5	0120000905200000000d4		1	0	0	0	32	0	9
24509	0004A30B00288390	2019-04-30 03:32:53	543	3	-76	SF10 BW125 4/5	011f000a03200000000d4		1	0	0	0	31	0	10
24494	0004A30B00288390	2019-04-30 01:32:51	542	3	-78	SF10 BW125 4/5	011e000b01200000000d5		1	0	0	0	30	0	11
24480	0004A30B00288390	2019-04-29 23:32:50	541	3	-77	SF10 BW125 4/5	011d000c17200000000d5		1	0	0	0	29	0	12
24465	0004A30B00288390	2019-04-29 21:32:48	540	3	-81	SF10 BW125 4/5	011c000e15200000000d4		1	0	0	0	28	0	14
24453	0004A30B00288390	2019-04-29 21:02:46	539	3	-76	SF10 BW125 4/5	011b000f15020000000c7		1	0	0	0	27	0	15
24439	0004A30B00288390	2019-04-29 20:32:43	538	3	-81	SF10 BW125 4/5	011a000f14200000000c7		1	0	0	0	26	0	15
24427	0004A30B00288390	2019-04-29 20:02:41	537	3	-76	SF10 BW125 4/5	0119000f14020000000c7		1	0	0	0	25	0	15
24413	0004A30B00288390	2019-04-29 19:32:38	536	3	-78	SF10 BW125 4/5	0118001013200000000c7		1	0	0	0	24	0	16
24401	0004A30B00288390	2019-04-29 19:02:35	535	3	-77	SF10 BW125 4/5	0117001113020000000c7		1	0	0	0	23	0	17
24387	0004A30B00288390	2019-04-29 18:32:33	534	3	-78	SF10 BW125 4/5	0116001112200000000c7		1	0	0	0	22	0	17
24375	0004A30B00288390	2019-04-29 18:02:30	533	3	-76	SF10 BW125 4/5	0115001212020000000c7		1	0	0	0	21	0	18
24361	0004A30B00288390	2019-04-29 17:32:27	532	3	-77	SF10 BW125 4/5	0114001211200000000c7		1	0	0	0	20	0	18
24349	0004A30B00288390	2019-04-29 17:02:25	531	3	-70	SF10 BW125 4/5	0113001211020000000c7		1	0	0	0	19	0	18
24335	0004A30B00288390	2019-04-29 16:32:22	530	3	-78	SF10 BW125 4/5	0112001210200000000c7		1	0	0	0	18	0	18
24316	0004A30B00288390	2019-04-29 16:02:20	529	3	-77	SF10 BW125 4/5	0011001110020000000000		0	0	0	0	17	0	17
24315	0004A30B00288390	2019-04-29 15:57:16	528	3	-95	SF10 BW125 4/5	871000110f39012c27e8c7	060f9330	7	1	0	0	16	0	17
24314	0004A30B00288390	2019-04-29 15:57:10	527	3	-89	SF10 BW125 4/5	870f00110f39012c27e8c7	060f9330	7	1	0	0	15	0	17
24300	0004A30B00288390	2019-04-29 15:40:03	526	3	-93	SF10 BW125 4/5	810e00110f2701242860c7		1	1	0	0	14	0	17

Figure : Database table example

Once data is stored on the database, you can use any compatible tool to query the database and develop your own data analysis and visualization. This task belongs entirely to the customer or system integrator.

Last packet received				
node_name	LW_EUI	Time	Frame_type	State
node_01	0004A30B00288390	2019-04-30 10:57:10	Keep alive	OCCUPIED
node_02	0004A30B00286556	2019-04-30 11:00:19	Keep alive	OCCUPIED
node_03	0004A30B0028A33A	2019-04-30 11:07:40	Keep alive	OCCUPIED
node_04	0004A30B00287F04	2019-04-30 11:00:01	Keep alive	OCCUPIED
node_05	0004A30B00287F01	2019-04-30 10:56:10	Keep alive	FREE
node_06	0004A30B0028600B	2019-04-30 11:20:00	Keep alive	FREE
node_07	0004A30B002612F1	2019-04-30 11:10:41	Keep alive	OCCUPIED
node_08	0004A30B0026425C	2019-04-30 11:02:57	Keep alive	OCCUPIED
node_09	0004A30B00268D81	2019-04-30 11:04:18	Keep alive	OCCUPIED
node_10	0004A30B0025EE61	2019-04-30 10:55:43	Keep alive	OCCUPIED
node_11	0004A30B002680BD	2019-04-30 11:01:36	Keep alive	OCCUPIED

Figure : Example of database visualization using Grafana (basic open-source application)

## 7.7. Modifying the Customer Server

Maybe you want to modify the Customer Server to match your requirements, this section describes the best way to do it.

### 7.7.1. Modifying the Database

If you want to use a database which is different to the provided one, or if you want to change the way data is saved on the database you must modify the file `src/app/Helpers/DataFlow.php`.

This class has 3 methods:

- **get\_null\_record**: This method should return an array of **NULL** values foreach field defined on the database.
- **get\_last\_record**: This method should return the previous record for the device. It should call the previous method if there isn't any previous value for the node.
- **insert\_record**: This method receives the data prepared to be inserted on the database as input and therefore it makes the database insertion on a new row.

### 7.7.2. Adding a new unsupported LoRaWAN Network Server

To add a new LoRaWAN Network Server (different from Loriot and Actility) you will have to create a new PHP class that must implement the interface located on `src/app/Helpers/Services/LwServiceInterface.php`. There are 4 methods to be implemented:

- **enqueue\_message**: It allows to send data to the new LoRaWAN Network Server.
- **get\_lw\_info\_from\_request**: It returns all the LoRaWAN information from the request of the new LoRaWAN Network Server.
- **get\_eui\_from\_request**: It returns the node EUI from the request of the new LoRaWAN Network Server.
- **get\_payload\_from\_request**: It returns the payload from the request of the new LoRaWAN Network Server.

The next step would be to create an endpoint to be able to receive data from the LoRaWAN Network Server. Therefore, you have to create a new method on the services app's controller:

---

```
src/app/Http/Controllers/api/v2/ServiceController.php
```

---

This method will receive a request object with all the data provided from the service, you can use the helper methods from the service class you have created previously. The implementation details can vary from service to service, so this cannot be explained in detail (you can use the Loriot and Actility ones as a reference).

The functionality that this method must implement is:

- Get data from the request
- Parse the payload using the same helper class used by the provided services:

---

```
$a_result = $this->frames->main($EUI, $payload);
```

---

- Enqueue the data if the parser returns something on the **output** key returned from the parser:

---

```
if($a_result['output']){  
    YourService::enqueue_message($EUI, $a_result['output']['data']);  
}
```

---

- Optionally, trigger an event to save the transaction to the database:

---

```
event(new \App\Events\DecoderEvent($a_result));
```

---

Once all steps have been completed you have to register the service on the file:

---

```
src/app/Providers/AppServiceProvider.php
```

---

The register method should pair LwService with the service you have just created.

## 8. Libelium Smart Parking Cloud Service

You can use the Libelium Cloud service to configure your nodes and to receive data from them. Using the Libelium Cloud Service you do not need any infrastructure on your side, you just need to purchase a Smart Parking Cloud Service license.

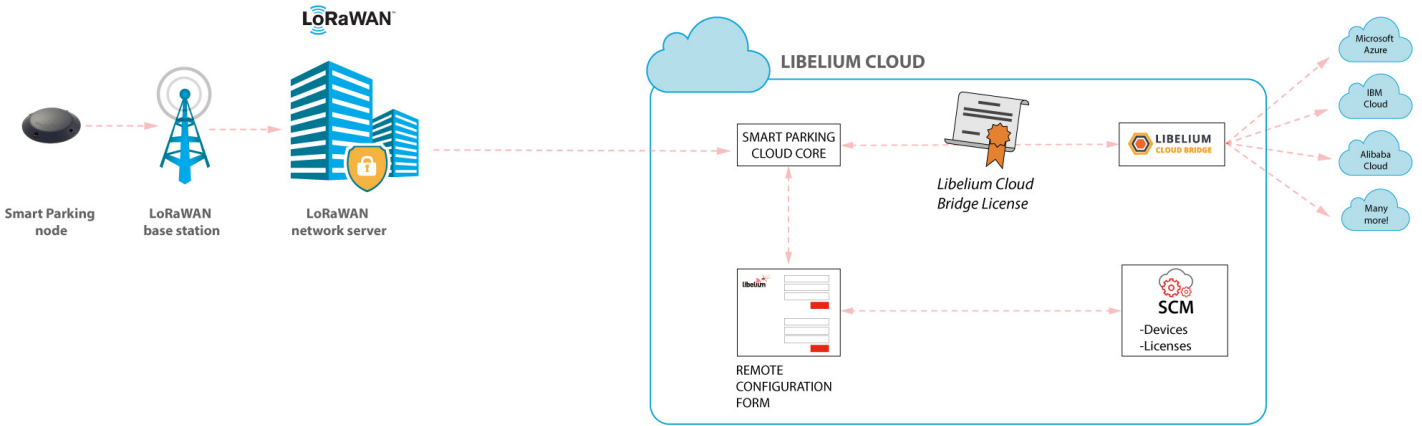

Figure : Smart Parking Cloud Service

The Smart Parking Cloud Service includes the Remote Configuration Form to manage the configuration values of the Smart Parking nodes, and the Smart Parking Cloud Core, that deals with the LoRaWAN network server requests, sending back a response if needed. The data sent from the Smart Parking nodes will be sent to any compatible final IoT cloud service using the Libelium Cloud Bridge (you will need a [license to use the Libelium Cloud Bridge](#)).

### 8.1. Smart Parking Cloud Service

Users can access this service clicking on the “Smart Parking” option through the left-side menu under the “Services” section. A valid licence is compulsory in order to work with this service.

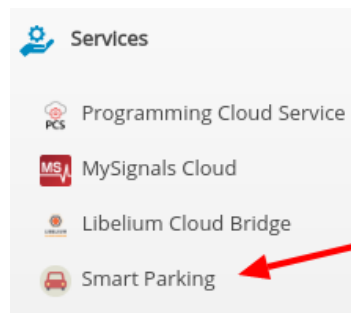

Figure : Accessing Smart Parking Cloud Service (1st way)

Another way to access the Smart Parking Cloud Service is possible through the collapsed menu at the top right of the page. Clicking on it and then on the “Smart Parking” option, users will arrive to the same place. As in the previous case, users must possess a valid license. Otherwise, this option will not be displayed.

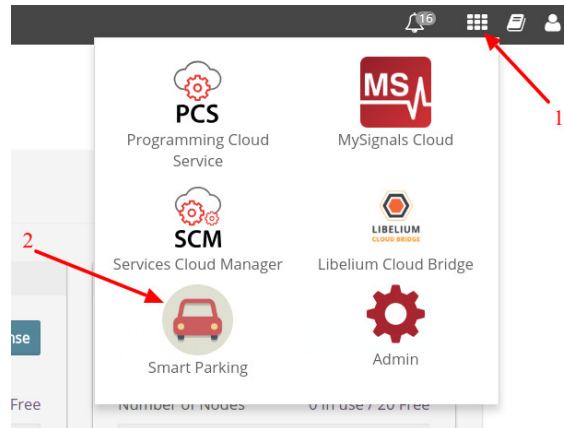

Figure : Accessing the Smart Parking Cloud Service (2nd way)

Once the user has a valid license, the following features will be available accessing the Smart Parking Cloud Service: configure nodes remotely, configure the LoRaWAN service, check the logs for the configured service and generate the tokens and keys needed for the LoRaWAN network server.

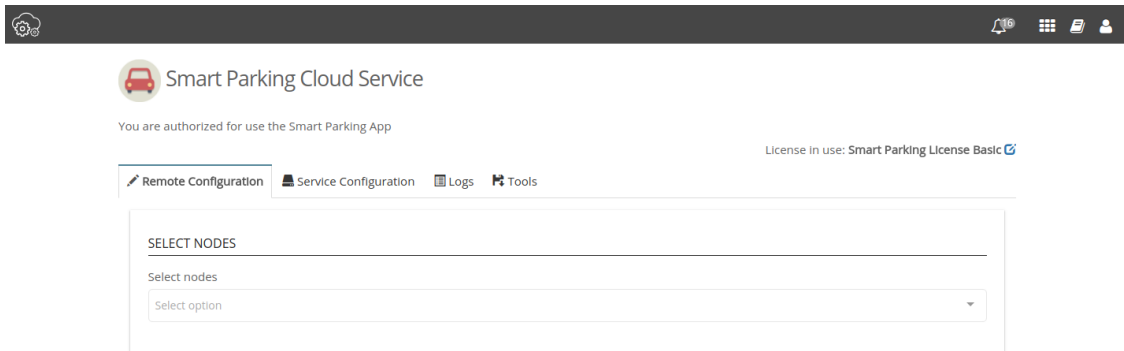

Figure : Smart Parking Cloud Service landing page

### 8.1.1. Remote Configuration

This tab shows a drop-down menu to select one or several devices. Each one is identified by their unique LoRaWAN EUI. The nodes displayed in the drop-down menu correspond to the nodes you have claimed for on your Services Cloud Manager account. You can also deselect previously selected nodes using the cross in the node’s identification. Once a node is selected, the current configuration of this node is displayed and you can modify it. For further information of the displayed node parameters, please refer to the chapter “Smart Parking node”.

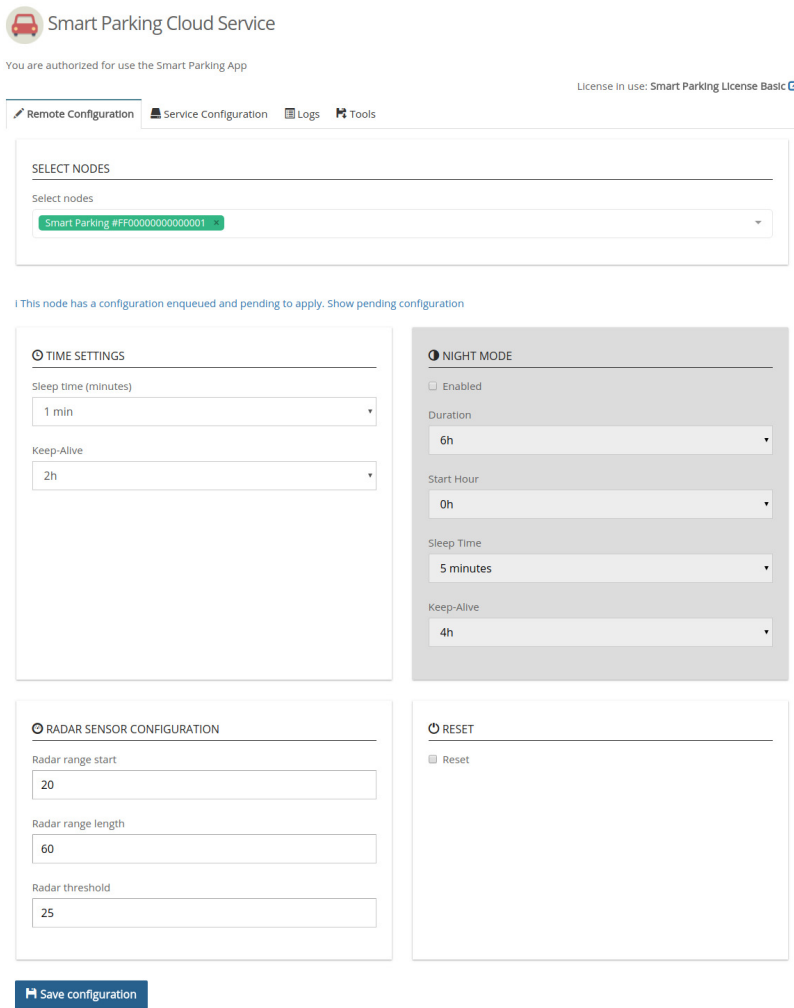

Figure : Remote Configuration Form

Once you have configured the node(s) and the service as explained in the section “[Service Configuration](#)”, press the “Save configuration” button. A message indicates that a downlink frame with the node’s configuration has been enqueued to the LoRaWAN Network Server downlink queue. The node will receive a downlink frame with the new configuration in response to the next Info or Keep-Alive uplink frame.

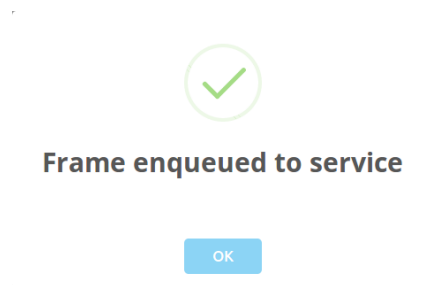

Figure : Frame enqueued for processing

The Remote Configuration Form application allows the user to update some node parameters just as the Smart Devices App does. However, using the Smart Devices App requires physical access to the node: it must be plugged to your computer via a USB cable.

**Note:** The Remote Configuration Form does not permit to update any LoRaWAN parameter. The Smart Devices App should be used instead.

## 8.1.2. Service Configuration

The Smart Parking Cloud Service is compatible with Lorient and Actility, but only one of these can be active at the same time.

If you want to use Lorient as your LoRaWAN Network Server, you have to select it on the drop-down menu and complete the required fields. To find the information on the Lorient panel, you can follow the instructions described on the [“How to configure Lorient”](#) section.

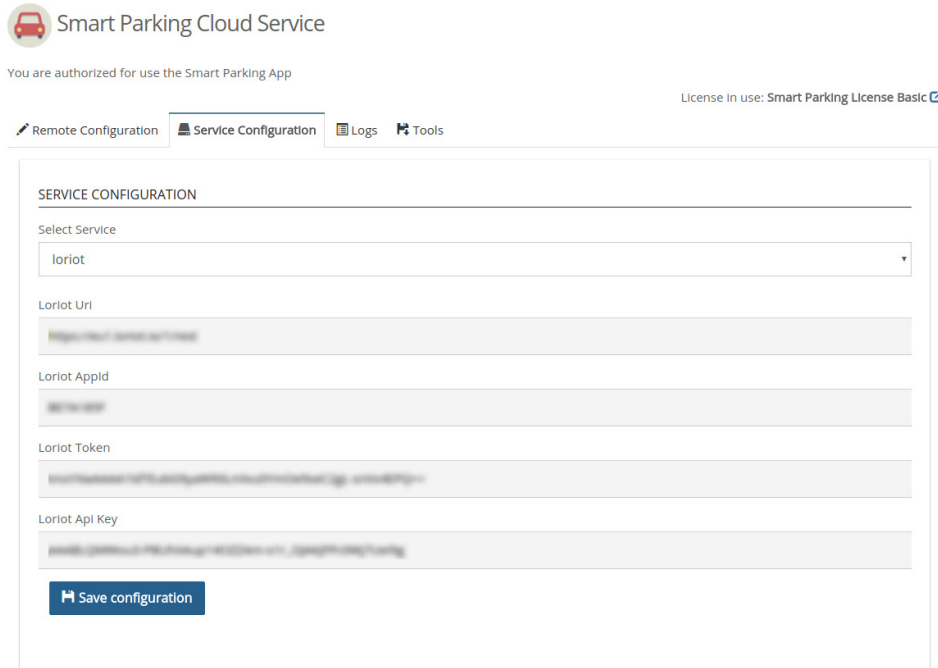

The screenshot shows the 'Smart Parking Cloud Service' configuration page. At the top, it says 'You are authorized for use the Smart Parking App' and 'License in use: Smart Parking License Basic'. Below this are navigation tabs: 'Remote Configuration', 'Service Configuration' (selected), 'Logs', and 'Tools'. The main content area is titled 'SERVICE CONFIGURATION' and contains the following fields:

- Select Service:** A dropdown menu with 'loriot' selected.
- Lorient Uri:** A text input field containing a URL.
- Lorient Appid:** A text input field containing an application ID.
- Lorient Token:** A text input field containing a token.
- Lorient Api Key:** A text input field containing an API key.

At the bottom of the configuration area is a blue button labeled 'Save configuration'.

Figure : Lorient configuration

If you want to use Actility as your LoRaWAN Network Server, you have to select it on the drop-down menu and complete the required fields. To find the information on the Actility panel, you can follow the instructions described on the [“How to configure Actility”](#) section.

Smart Parking Cloud Service

You are authorized for use the Smart Parking App

License in use: [Smart Parking License Basic](#)

Remote Configuration Service Configuration Logs Tools

**SERVICE CONFIGURATION**

Select Service  
activity

Activity Uri  
[Redacted]

Activity Token  
[Redacted]

Uplink/downlink security  
[Redacted]

AS\_ID: 10

Save configuration

Figure : Activity configuration

Regardless of the service you have configured, click on the button “Save Configuration” to save your LoRaWAN service configuration. Then, a message will be displayed indicating that the service has been updated or saved correctly.

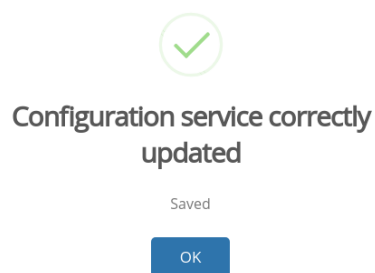

Figure : Service configuration saved

### 8.1.3. Log

The “Logs” tab shows the information and error messages registering the result of the communication requests of the LoRaWAN services. Different communication protocols are used to configure the service. All messages related to the transport layer of the service are identified as INFO or ERROR. User intervention may be required to analyse the meaning of the messages generated in the application layer and decide if some actions are required.



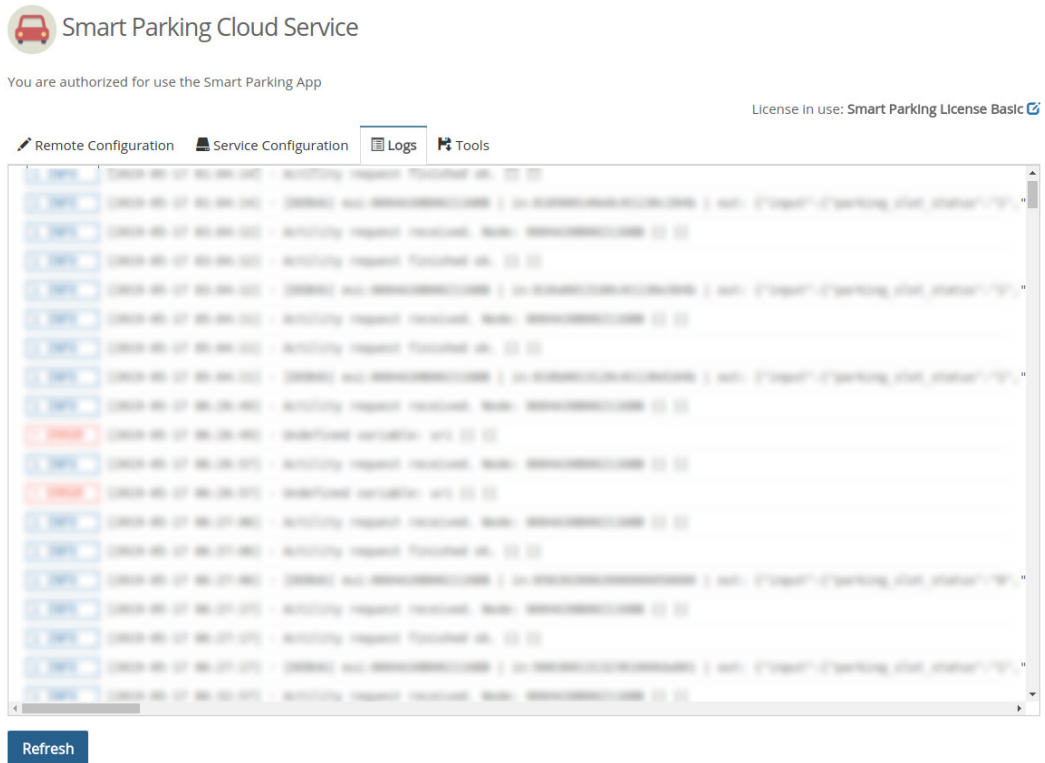

Figure : Log viewer

Click the “Refresh” button to update the log view and load new messages available. The latest messages appear at the bottom of the viewer.



Figure : “Refresh” button

### 8.1.4. Tools

The “Tools” tab allows users to download the Device Node Keys associated with their account, as well as generate the necessary token to configure your Loriot network server correctly.

Smart Parking Cloud Service

You are authorized for use the Smart Parking App

License in use: [Smart Parking License Basic](#)

[Remote Configuration](#) [Service Configuration](#) [Logs](#) [Tools](#)

**DOWNLOAD NODE KEYS**

Use this button for download the Node configuration keys to use in the LoRaWan panels.

[Download Node Keys](#)

Personal API Keys [Create New Key](#)

Name
Loriot

[Show](#) [Delete](#)

Figure : Tools

The Node Keys is a CSV-format file. It is ready to use in the LoRaWAN Network Server to configure all the Smart Parking nodes associated with their account in the Libelium Cloud. It can be downloaded by clicking on the "Download Nodes Keys" button.

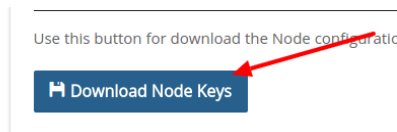

Figure : "Download Nodes Keys" button

Finally, a token must be generated clicking on the "Create New Key" link in order to finish the Loriot service configuration.

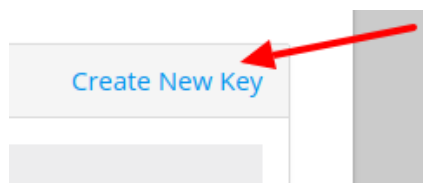

Figure : "Create New Key" link

A pop-up window will be displayed, in which users must introduce a name to identify the new token. Then, clicking the "Create" button shows a password in a new window, ready to be used in the Loriot service.

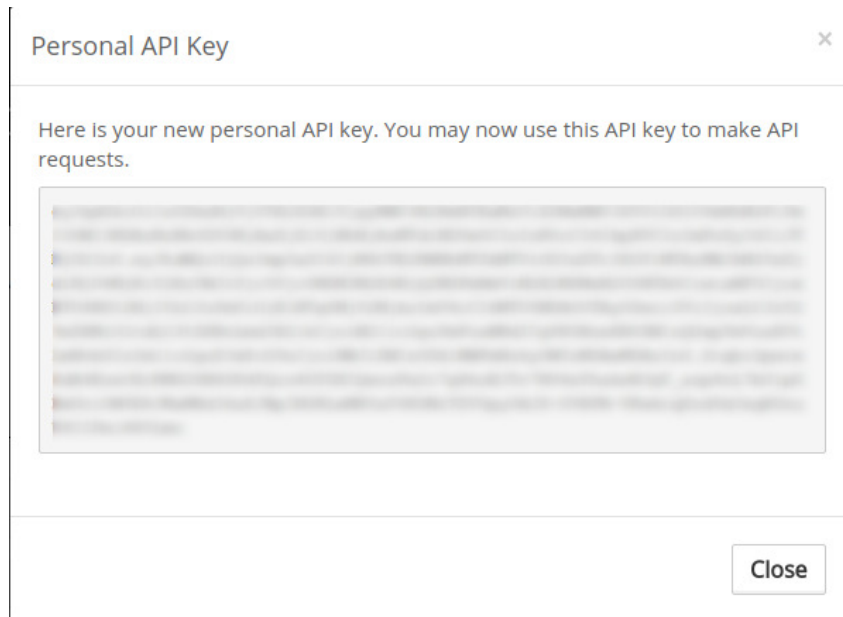

Figure : Generated key

Once the token has been generated, you can use it on the Lorient backend as described in the section: ["Manage Lorient output data"](#).

## 9. Deployment and installation

### 9.1. Step-by-step guideline

Once you receive the Smart Parking batch, the steps involved in the deployment of the network are:

1. **Nodes provisioning:** Once the client owns a LoRaWAN Network Server license, it is mandatory to register the nodes with the configured identifier and keys for each node. The client must decide whether they use the factory default LoRaWAN unique identifier and random private keys provided by Libelium or they prefer to configure their own identifier and keys. You must keep in mind that every node is provided "ready to install" with factory default identifier and keys. If client-configured identifier and keys are desired, then each node will have to be configured separately using the Smart Devices App. This 2nd option increases the provisioning time. So Libelium recommends to use the default IDs and keys. If factory default keys are used, then a CSV file exported from Libelium Cloud Services Manager (SCM) can be used to ease the bulk import into the LoRaWAN Network Server.

Please refer to the "Smart Devices App" chapter for further information about the Smart Devices App.

Please refer to the "Libelium Cloud management" chapter for further information about how to extract the factory default IDs/keys.

2. **Libelium Cloud or Customer Server setup:** The client must have chosen the type of cloud service to be used: The Libelium Cloud or her own Customer Server. The Libelium Cloud is used to receive and forward data to a 3rd party cloud system and the Customer Server is used to receive and store data. So depending on the end-point used, the LoRaWAN Network Server must be configured to properly forward all packets to the desired server.
3. **Nodes installation:** Each node must be placed on the proper parking slot and then follow the "magnet start-up" protocol explained in the "Magnet start-up" process" section.

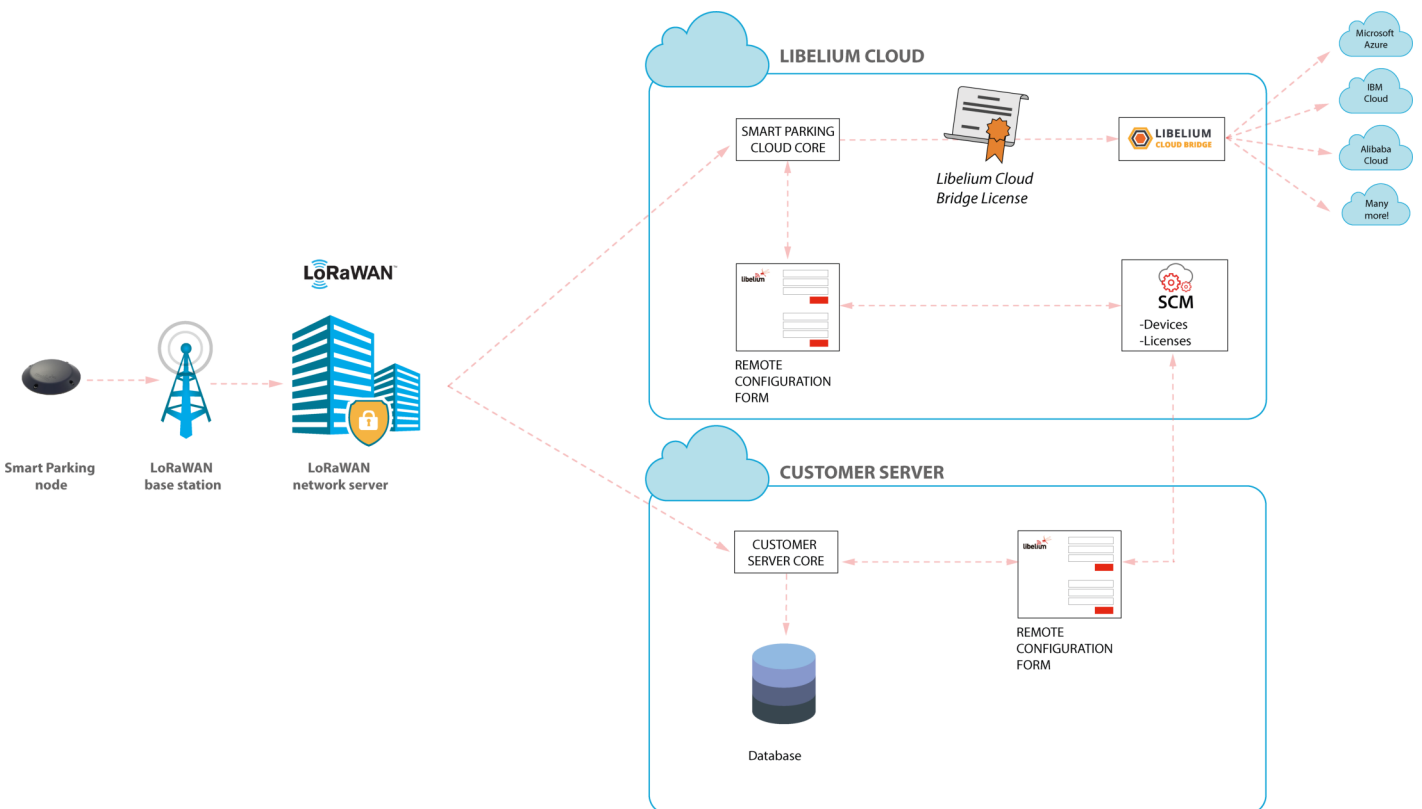

Figure : Smart Parking network architecture

## 9.2. How to place the nodes

The correct installation spot is the center of the parking slot to ensure the best detection. It is possible to install the nodes on different parking slot configurations:

- Parallel
- Perpendicular
- Angled

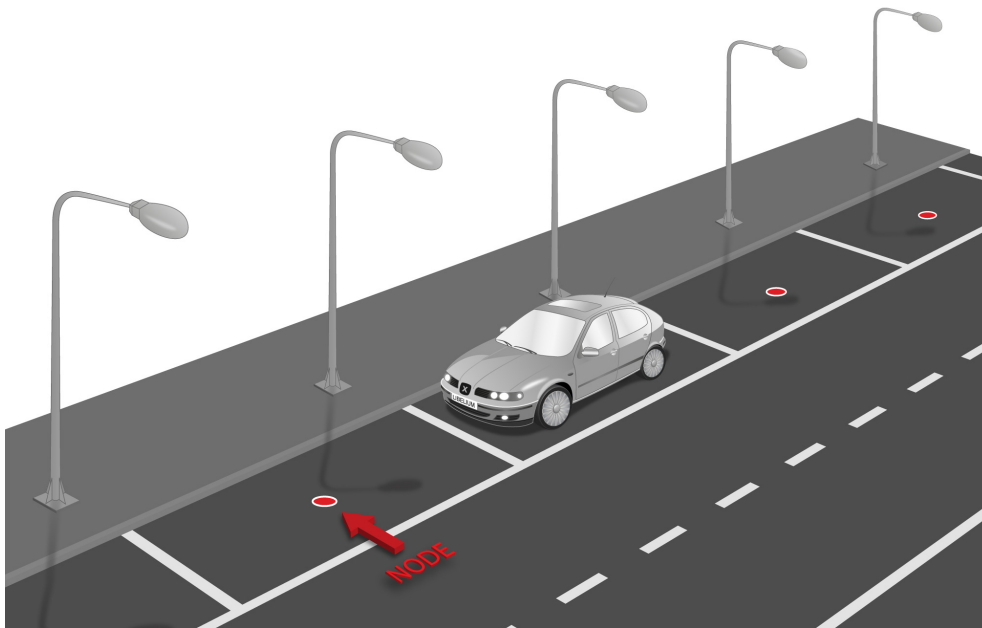

Figure : Parallel parking slots

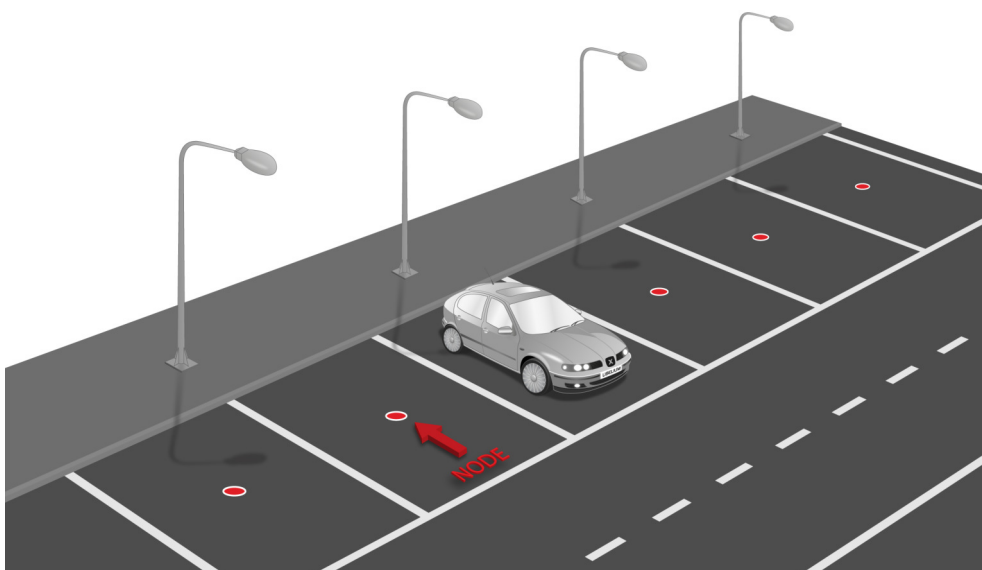

Figure : Perpendicular parking slots

**Important:**

*It is important to keep in mind that parking slots must be delimited by lines so the node is placed in the center of the parking area. Placing the nodes with no line definitions may lead into bad behaviour.*

## 9.3. Node installation

### 9.3.1. Triple installation option

The user can choose among the 3 types of installation for the node. This table summarizes pros and cons:

	On-surface installation	Semi-underground installation	Underground installation
Type of enclosure	Vaulted	Vaulted	Flat
Presence of node over the ground	Full node (40.25 mm)	Part of node (6 mm)	Node completely buried (0 cm)
Rain immunity	Yes	Yes	Partial
Puddle immunity	Yes	Yes	Detection may fail if puddle appears
Vandalism/robbery immunity	Medium	High	High
Snowplow immunity	No	Possible	Yes
Installation process	Fast and easy	Special tools needed	Special tools needed
Tools needed	Normal drill	Industrial big crown drill. Epoxy.	Industrial big crown drill. Epoxy.
Can be dismantled for maintenance	Yes	No	No

### 9.3.2. On-surface node installation

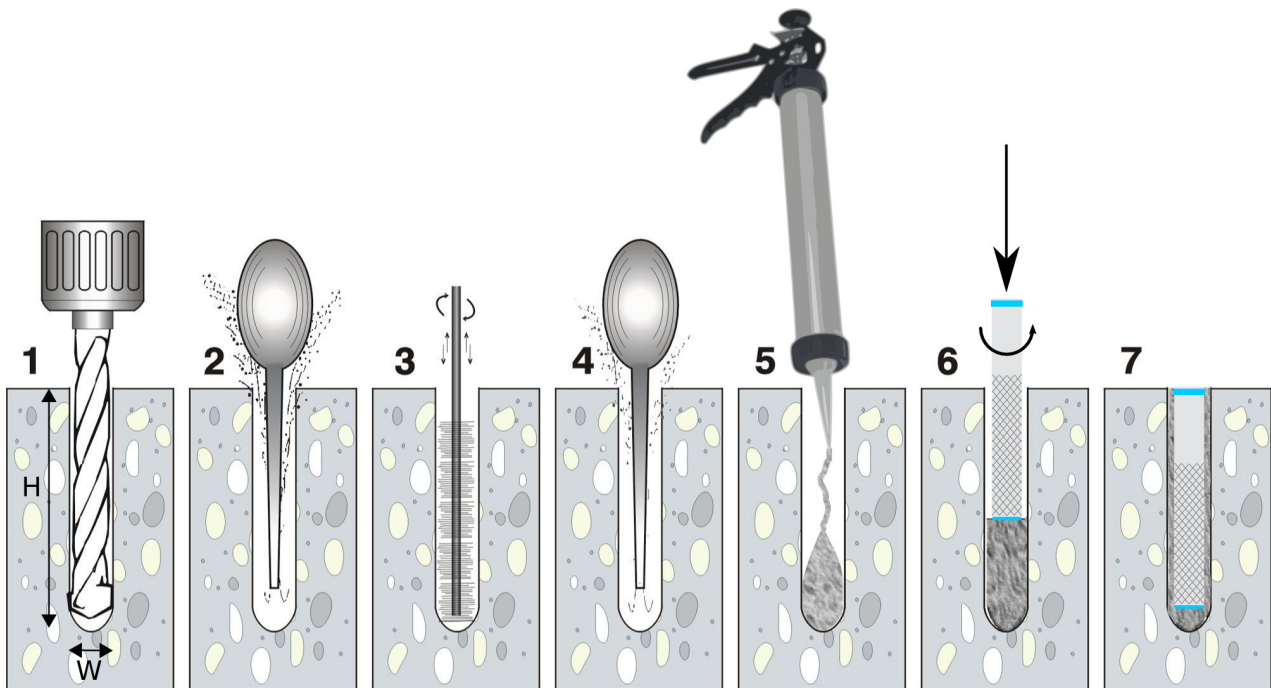

Figure : Step by step chemical fixing and anchor installation

Firstly, mark 4 holes in the asphalt. Select an area as flat and regular as possible, avoid irregularities on the terrain. You should place the enclosure in the final location and use the 4 holes as a reference to drill 4 little marks on the ground. You can also draw 4 dots with ink.



Figure : Marking the holes for the node

Then continue with the chemical fixing installation step by step as described above. Also, in the next video you can see how the installation is done [chemical fixing installation](#).

**Step 1:** Drill the holes.

The drill diameter must be  $W=14$  mm minimum. Try to drill as vertical as possible to enable the best enclosure installation. The length of the hole must be about  $H=85$  mm.





Figure : Drill the holes (step 1)

**Step 2, 3 and 4:** Blow out dust and loose materials.

Remove all the dust and little rocks inside the 4 holes, created during the drilling operation. This is important to allow the anchors go all the way down. You can clean each hole mechanically and then use a bottle of spray duster (high-pressure air bottle). Make sure that the real depth of the hole is enough.



Figure : Brush the hole (step 3)



Figure : Blow out dust and loose materials (steps 2 and 4)



**Step 5:** Inject the chemical fixing.

The chemical fixing shall be injected into the 4 holes carefully. You must keep in mind that this chemical adhesive must fill the complementary space the anchor leaves in the hole. So the whole hole does not have to be fully filled with adhesive because there is no space left for the anchor. The chemical adhesive quantity to be injected will depend on the dimensions of the holes.



Figure : Inject chemical fixing adhesive (step 5)

**Step 6:** Insert the anchors.

Once the adhesive is injected, the anchor must be carefully inserted into the hole. Rotating the anchor by hand while inserting it is a good practice. Therefore, the adhesive fills and completes all the empty space left by the anchor in the hole.

Once the anchor is correctly inserted, some adhesive might exceed from the hole. This residuary adhesive must be removed from the installation so there are no extra adhesive and the anchor installation is clean and smooth.



Figure : Insert the anchors (step 6)

**Step 7:** Finish anchors installation.

The anchors have an internal thread to screw the screws. Inserting the anchors with the screws partially inserted might be a good practice in order to place the anchor correctly aligned within the hole (that means you can use the screw as a tool if it is partially inserted inside the anchor). Also, if the screw is inside the anchor, avoids that the adhesive accidentally gets inside the anchor. After cleaning the remaining adhesive from the hole, the user must wait some time until the chemical resin is solid and stable. After this period of time, the screws can be removed from the anchors and the installation is finished.





Figure : Final anchor installation (step 7)

**Step 8:** Place the node.

Place the black rubber circle on the ground. To enable the correct screwing of the screws inside the anchors, make sure that there is no dust in the internal thread of the anchor. Install the node in its final position and screw the 4 special (anti-vandalism) screws provided. Anti-vandalism screws are recommended to avoid problems: anyone could unscrew a node if fixed with standard screws.



Figure : Place the circle rubber and the node above it



Figure : Screw the node



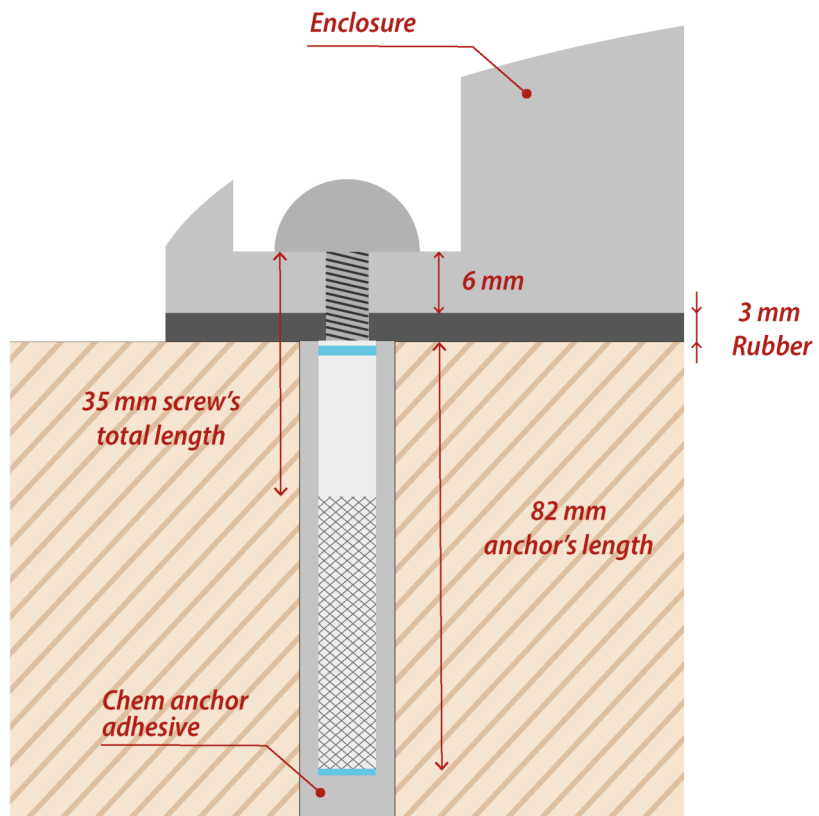

Figure : Final section of the anchor and screw

### 9.3.3. Underground node installation

Depending on the scenario, placing the node under the pavement can be a must. In cold places where snow is usual, installing the nodes underground permits the use of snowplow equipment without affecting the Smart Parking node. Also, this kind of installation allows the client to deploy much safer networks against vandalism or theft as the device is not accessible directly from the outside.



Figure : Snowplow vehicle

For this special installation, Libelium provides flat enclosures. Contact your Sales agent to order flat enclosures.

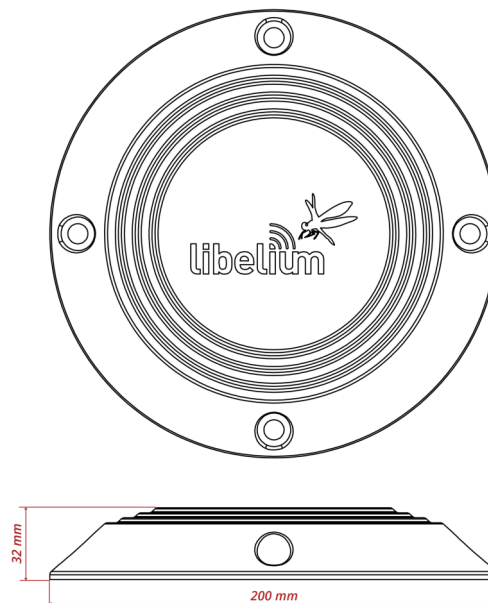

Figure : Flat Smart Parking enclosure dimensions

Regarding the installation process, the next steps explain how to correctly install the device under the ground:

**Step 1:** Drill the hole.

Use a hole saw or other dedicated tool to drill a hole into the pavement bigger enough for the enclosure (minimum diameter 202 mm). Try to perforate it deep enough to insert the Smart Parking node completely without rising over the surface, be sure that the enclosure remains under the pavement line approximately 10 mm.



Figure : Making a hole in the pavement

**Step 2:** Place the node into the pavement hole.

Below the device, a layer of cement must be spread to elevate the device to the correct horizontal position independently of the depth of the hole. The diameter of the hole must be at least 202 mm.

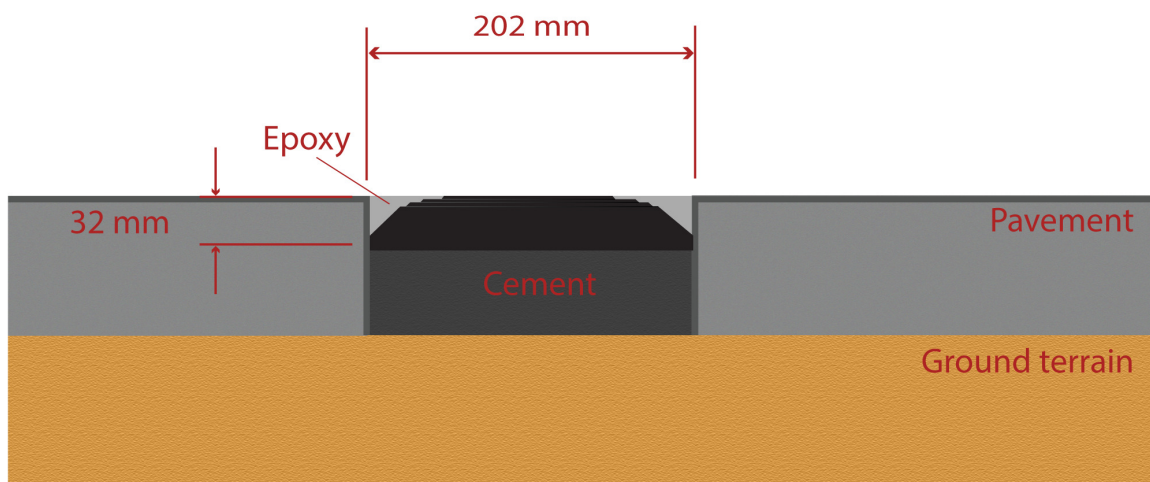

Figure : Placing the node in the hole

**Step 3:** Fill the hole.

Finally, the node needs to be fixed to the pavement using Epoxy resin (commonly used for filling road fissures). This resin should fill all the space between enclosure and pavement. Also, it should completely cover the top of the enclosure ensuring protection against water, bad environmental conditions and vandalism. The Epoxy resin tested by Libelium provides a curing time around 6-12 hours at 20 °C and RH 50%. So the parking installation must not be used prior this curing time.





*Figure : Pour Epoxy curing agent into the granular resinous material*



*Figure : Preparing the Epoxy resin mixture*

In this installation, it is crucial that the upper side of the enclosure is not covered with Epoxy or other material. Only the side slides can be covered, the center of the node must be clean to allow the radar signal work properly.



*Figure : Final Epoxy application*

**Step 4:** Start the node using the magnet.  
Proceed with the "Magnet start-up" process in order to initialize the node.

### 9.3.4. Semi-underground node installation

This is a possible installation in order to provide vandalism immunity and also rain/puddle immunity. So the node is partially inserted in the ground and the vaulted enclosure minimizes the water issues.

The same underground installation steps must be followed as seen in the previous section. In the node placement step, the vaulted enclosure must exceed the horizontal pavement layer by 6-7 mm approximately. The next figure shows how the node is placed:

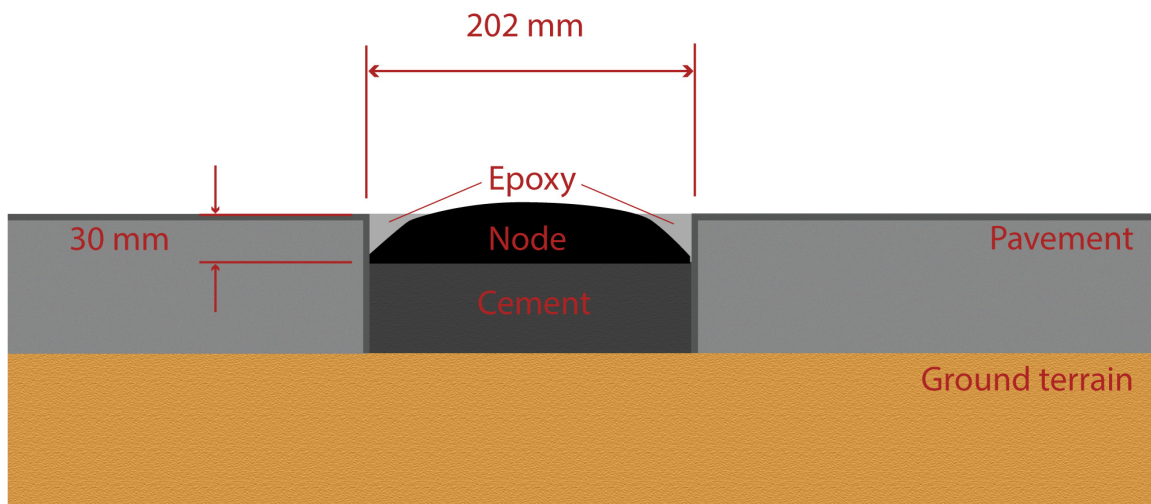

Figure : Semi-underground node installation

## 9.4. Node start-up

After the node is installed, you must follow the "Magnet start-up" steps explained in the "Magnet start-up process" section. This process is based on 3 consecutive magnet resets waiting at least one second between each reset. In the future need of resetting the node manually, just a single magnet reset will be needed.

Once the node has been started, it will begin to run the firmware step-by-step as explained in the "How the node works" section.

In the next video you can see how the "magnet start-up" is performed: [magnet start-up](#).



*Figure : Using the magnet to start the node*



## 9.5. Working example

The next diagram explains how the node program works when the node is installed and started when the parking slot is free. On the left column you can appreciate the parking lot status during the execution. On the right side you can see the frame types that are sent to the Libelium Cloud or Customer Server depending on: parking slot status changes, elapsed time and user configuration changes.

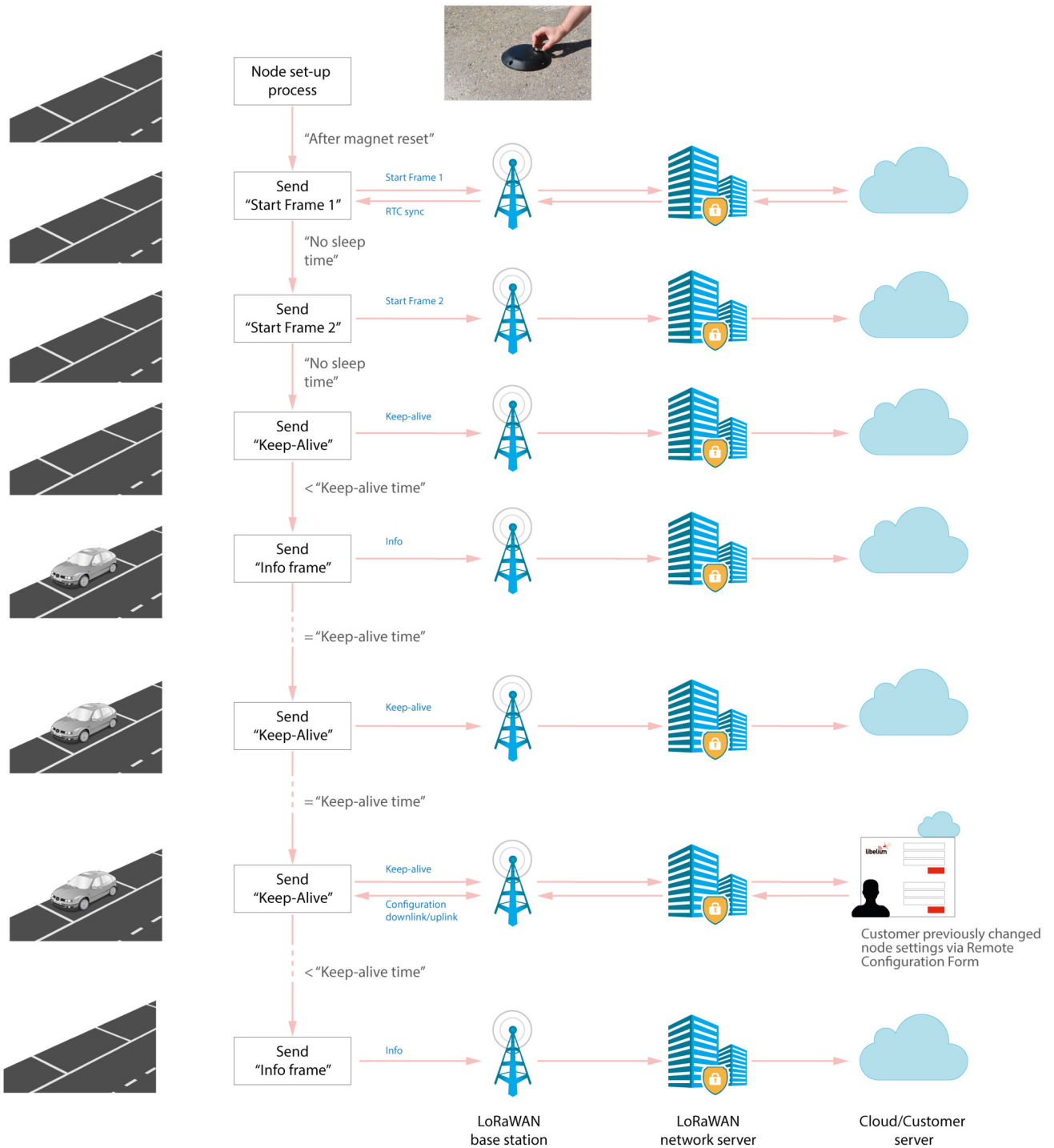

Figure : Smart Parking node working example

## 10. Certifications

### 10.1. CE (European Union)

In accordance with the RED Directive, Libelium Comunicaciones Distribuidas S.L. declares that the “Smart Parking v2 EU” device is in conformity with the European Union legislation and with the following harmonized standards and technical specifications:

- EN 50581:2012
- EN 301 489-1 Ver. 2.1.1 (2017-02)
- EN 301 489-3 Ver. 2.1.1 (2017-03)
- EN 305 550-2 V1.2.1 (2014-10)
- Draft EN 305 550 V2.1.0 (2017-10)
- EN 300 220-1 V3.1.1 (2016-11)
- EN 300 220-2 V3.1.1 (2016-11)
- EN 62479:2011
- UNE-EN 62368-1:2014 + AC:2015 + AC1:2015 + AC2:2015 + AC:2017-03 + A11:2017

### 10.2. FCC (United States)



“Smart Parking v2 US” complies with Title 47 Part 15 subpart B of the FCC rules and regulations for Radio Frequency Devices – Unintentional Radiators (2019). This device contains the following transmitter modules:

- FCC ID: T9JRN2903
- FCC ID: 2AQ6KA1

If you want to know more, contact the Libelium Sales Department.

# 11. Safety Guides

## 11.1. Smart Parking Chemical Fixing Cartridge

Material Safety Data Sheet as per regulation (EC) 1907/2006		<b>fischer</b> <small>innovative solutions</small>
Commercial Product Name: FIS P 300 T	Revision date: 30.07.2013	Version: 3.2/en Print date: 30.07.2013
<b><u>SECTION 1: Identification of the substance/mixture and of the company/undertaking</u></b>		
<b>1.1 Product identifier</b>		
Commercial Product Name	FIS P 300 T	
<b>1.2 Relevant identified uses of the substance or mixture and uses advised against</b>		
Relevant identified uses	composite mortar	
Recommended restrictions	None under normal processing. Observe technical data sheet.	
<b>1.3 Details of the supplier of the safety data sheet</b>		
Company designation	fischerwerke GmbH & Co. KG Weinhalde 14-18 D-72178 Waldachtal Telephone: +49(0)7443 12-0 FAX: +49(0)7443 12-4222 Email: info-sdb@fischer.de	
Marketer	Great Britain: Mrs Mirka Valovicova, fischer Fixing (UK) Ltd, Hithercroft Road, Wallingford, Oxfordshire, OX10 9AT, Tel. 01491 827 920, Fax 01491 827 950	
<b>1.4 Emergency telephone number</b>		
Emergency telephone number	+49(0)6132-84463 (24h)	
<b><u>SECTION 2: Hazards identification</u></b>		
<b>2.1 Classification of the substance or mixture</b>		
Classification according to Regulation (EC) No. 1272/2008	Skin Irrit. 2; H315 Eye Dam. 1; H318 Skin Sens. 1; H317	
Classification according to Directive 67/548/EEC / 1999/45/EEC	R43 Xi; R41	
<b>2.2 Label elements</b>		
Hazard pictogram		
	GHS05	GHS07
Signal word	Danger	

**Material Safety Data Sheet as per regulation (EC)**

**1907/2006**

Commercial Product Name: FIS P 300 T

Revision date: 30.07.2013

Version: 3.2/en

Print date: 30.07.2013

Hazardous component(s) to be indicated on label	portland cement, 2-hydroxypropyl methacrylate, dibenzoyl peroxide
H-statement(s)	H315: Causes skin irritation. H317: May cause an allergic skin reaction. H318: Causes serious eye damage.
P-statement(s)	P101: If medical advice is needed, have product container or label at hand. P102: Keep out of reach of children. P280: Wear protective gloves/protective clothing/eye protection/face protection. P305+P351+P338: IF IN EYES: Rinse cautiously with water for several minutes. Remove contact lenses, if present and easy to do. Continue rinsing. P310: Immediately call a POISON CENTER or doctor/physician.

**2.3 Other hazards**

Health hazard	None known.
Particular information pertaining specific risk for human / environment	None known.
Indication of danger	None known.
Hazard precautions	None known.

**SECTION 3: Composition/information on ingredients**
**Hazardous ingredients**

Ingredient	CAS No.: EC-No.: Index-No.:	Classification (EEC) No 67/548	Concentration
		Classification (EC) 1272/2008	
Quartz (SiO <sub>2</sub> )	CAS No.: 14808-60-7 EC-No.: 238-878-4		25.0 - 50.0 % by weight
portland cement	CAS No.: 65997-15-2 EC-No.: 266-043-4	Xi; R37/38-41 Skin Irrit. 2; H315 Eye Dam. 1; H318 Skin STOT SE 3; H335	10.0 - 25.0 % by weight
2-hydroxypropyl methacrylate	CAS No.: 27813-02-1 EC-No.: 248-666-3 Index-No.: 607-125-00-5	R43 Xi; R36 Eye Irrit. 2; H319 Skin Sens. 1; H317	< 2.5 % by weight
ethanediol, ethylene glycol	CAS No.: 107-21-1 EC-No.: 203-473-3 Index-No.: 603-027-00-1 REACH No.: 01-2119456816-28-xxxx, 02-2119752517-33-xxxx	Xn; R22 Acute Tox. 4; H302 STOT RE 2; H373	< 2.5 % by weight
dibenzoyl peroxide	CAS No.: 94-36-0 EC-No.: 202-327-6 Index-No.: 617-008-00-0 REACH No.: 01-2119511472-50-xxxx	E; R3 O; R7 Xi; R36 R43 Org. Perox. B; H241 Eye Irrit. 2; H319 Skin Sens. 1; H317	< 2.5 % by weight
2-methoxy-1-methylethyl acetate	CAS No.: 108-65-6 EC-No.: 203-603-9 Index-No.: 607-195-00-7	R10 Flam. Liq. 3; H226	< 2.5 % by weight





**Material Safety Data Sheet as per regulation (EC)**



1907/2006

Commercial Product Name: FIS P 300 T

Revision date: 30.07.2013

Version: 3.2/en

Print date: 30.07.2013

Keep containers and surroundings cool with water spray.

**SECTION 6: Accidental release measures**

**6.1 Personal precautions, protective equipment and emergency procedures**

Personal precautions                      Ensure adequate ventilation, especially in confined areas.  
 Keep people away from and upwind of spill/leak.

**6.2 Environmental precautions**

Environmental precautions              The product should not be allowed to enter drains, water courses or the soil.  
 Prevent spreading over a wide area (e.g. by containment or oil barriers).

**6.3 Methods and material for containment and cleaning up**

Methods for cleaning up                  Use mechanical handling equipment.  
 Treat recovered material as described in the section "Disposal considerations".

**6.4 Reference to other sections**

Reference to other sections              See chapter 8/13

**6.5 Additional information**

Other information                          Dispose of in accordance with local regulations.

**SECTION 7: Handling and storage**

**7.1 Precautions for safe handling**

Advice on safe handling                  None under normal processing.  
 Caution: During machining in cured state dust is formed.

Advice on protection against fire and explosion      No special precautions required.

**7.2 Conditions for safe storage, including any incompatibilities**

Storage space and container requirements      Keep containers tightly closed in a cool, well-ventilated place.  
 Store in accordance with local regulations.  
 Keep only in original container.

Hints on storage assembly                  Store in accordance with the particular national regulations.

German storage class                      10-13 (TRGS 510)

**7.3 Specific end use(s)**

Specific use(s)                                  composite mortar  
 Further information: see technical data sheet.

**Material Safety Data Sheet as per regulation (EC)**

1907/2006

Commercial Product Name: FIS P 300 T

Revision date: 30.07.2013

Version: 3.2/en

Print date: 30.07.2013

**SECTION 8: Exposure controls /personal protection**
**8.1 Control parameters**
**portland cement**

Great Britain

Long-term exposure value/ mg/ m3	Remarks	Source
10	inhalable dust	100
4	respirable dust	100

100 - Firmendaten

**ethanediol, ethylene glycol**

Great Britain

Long-term exposure value/ mg/m3	Remarks	Long-term exposure value/ ppm	Short-term exposure value / ppm	Short-term exposure value / mg/m3	Source
10	particulate,Sk R22				19
52	vapour, Sk, R22	20	40	104	19

19 - EH40/200 Workplace exposure limits (October 2007)

Europe

Long-term exposure value/ mg/ m3	Long-term exposure value/ ppm	Short-term exposure value / mg/ m3	Short-term exposure value / ppm	Note	Issuing date	Source
52	20	104	40	Skin	2000/39	24

24 - DIRECTIVE 2009/161/EU

DNEL

Value	Target group	Exposure route	Exposure frequency	Source
35 mg/m <sup>3</sup>	Workers	Inhalation	Long term effects	100
106 mg/kg	Workers	dermal	Long term effects	100
7 mg/m <sup>3</sup>	consumer	Inhalation	Long term effects	100
53 mg/kg	consumer	dermal	Long term effects	100

100 - Firmendaten

PNEC

Value	Target group	Source
10 mg/l	freshwater	100
1 mg/l	marine water	100
199,5 mg/l	PNEC sewage treatment plant (STP)	100
20,9 mg/kg	PNEC sediment, freshwater	100
1,53 mg/kg	Soil	100

100 - Firmendaten

**dibenzoyl peroxide**

Great Britain

Long-term exposure value/ mg/ m3	Remarks	Source
5	R2, 36, 43	19

19 - EH40/200 Workplace exposure limits (October 2007)

**Material Safety Data Sheet as per regulation (EC)**



1907/2006

Commercial Product Name: FIS P 300 T

Revision date: 30.07.2013

Version: 3.2/en

Print date: 30.07.2013

**2-methoxy-1-methylethyl acetate**

Great Britain

Long-term exposure value / ppm	Long-term exposure value / mg/m <sup>3</sup>	Short-term exposure value / ppm	Short-term exposure value / mg/m <sup>3</sup>	Remarks	Source
50	274	100	548	Sk R10, 36	19

19 - EH40/200 Workplace exposure limits (October 2007)

Europe

Long-term exposure value / mg / m <sup>3</sup>	Long-term exposure value / ppm	Short-term exposure value / mg / m <sup>3</sup>	Short-term exposure value / ppm	Note	Issuing date	Source
275	50	550	100	Skin	2000/39	24

24 - DIRECTIVE 2009/161/EU

**8.2 Exposure controls**

Respiratory protection	No personal respiratory protective equipment normally required.
Hand protection	not required under normal use
Suitable material:	butyl-rubber, Chloroprene, Nitrile rubber
Unsuitable material:	PVC disposable gloves
Material thickness:	adjust to application and duration of use
Break through time:	adjust to application and duration of use
Remarks:	Take note of the information given by the producer concerning permeability and break through times, and of special workplace conditions (mechanical strain, duration of contact).
Reference substance:	Replace when worn.
Eye protection	Tightly fitting safety goggles
Skin and body protection	Wear suitable protective equipment.
Note:	Choose body protection according to the amount and concentration of the dangerous substance at the work place.
General protective and hygiene measures	Smoking, eating and drinking should be prohibited in the application area. Avoid contact with skin, eyes and clothing. Take off all contaminated clothing immediately. Wash hands before breaks and at the end of workday. Keep away from food, drink and animal feedingstuffs. Use protective skin cream before handling the product.
Information on environmental protection regulations	No special environmental precautions required.



**Material Safety Data Sheet as per regulation (EC)**

1907/2006

Commercial Product Name: FIS P 300 T

Revision date: 30.07.2013

Version: 3.2/en

Print date: 30.07.2013

**SECTION 9: Physical and chemical properties**
**9.1 Information on basic physical and chemical properties**

Form	paste
Colour	grey
Odour	characteristic
Odour threshold	not determined
pH	No data available
Melting point [°C]	No data available
Boiling point [°C]	no data available
Flash point [°C]	> 100 °C
Evaporation rate [kg/(s*m <sup>2</sup> )]	No data available
Flammability	No data available
Explosion limits [Vol-%]	
Lower limit:	not determined
Upper limit:	not determined
Risk of explosion.	Not explosive
Vapour pressure [kPa]	No data available
Density [g/cm <sup>3</sup> ]	1,7 - 1,9 g/cm <sup>3</sup>
Temperature:	20 °C
Water solubility [g/l]	not determined
Solubility [g/l]	No data available
Partition coefficient n-octanol / water (log P O/W)	No data available
Autoinflammability	not auto-flammable
Decomposition temperature [°C]	not determined
Viscosity, dynamic [kg/(m*s)]	180 - 240 Pas
Temperature:	20 °C

**9.2 Other information**

Relative vapour density (air=1)      not determined

**SECTION 10: Stability and reactivity**
**10.1 Reactivity**

Thermal decomposition                  No decomposition if stored and applied as directed.

**Material Safety Data Sheet as per regulation (EC)**

1907/2006

Commercial Product Name: FIS P 300 T

Revision date: 30.07.2013

Version: 3.2/en

Print date: 30.07.2013

**10.2 Chemical stability**

Chemical stability                      Stable under recommended storage conditions.

**10.3 Possibility of hazardous reactions**

Hazardous reactions                      No dangerous reaction known under conditions of normal use.

**10.4 Conditions to avoid**

Conditions to avoid                      No decomposition if used as directed.

**10.5 Incompatible materials**

Materials to avoid                      Not applicable.

**10.6 Hazardous decomposition products**

 Hazardous decomposition prod-      No decomposition if used as directed.  
ucts

**SECTION 11: Toxicological information**
**11.1 Information on toxicological effects**

Oral toxicity [mg/kg]

Value	Test criterion	Test species	Remarks
> 5000	LD50	rat	dibenzoyl peroxide (CAS 94-36-0)
keine - literature value			portland cement (CAS 65997-15-1)
> 5000	LD50	rat	2-hydroxypropyl methacrylate (CAS 27813-02-1)

Dermal toxicity [mg/kg]

Value	Test criterion	Test species	Duration	Remarks
> 5000	LD50	rabbit		ethanediol (CAS 107-21-1)
> 2000	LC50	rabbit	24 h	portland cement (CAS 65997-15-1)
> 5000	LD50	rabbit		2-hydroxypropyl methacrylate (CAS 27813-02-1)

Inhalative toxicity [mg/l]

Value	Test criterion	Duration of dosage	Test species	Note
4000	LD50		rat	ethanediol (CAS 107-21-1)
> 243000	LC50		rat	dibenzoyl peroxide (CAS 94-36-0)
> 5	LD50	Limit Test.	rat	portland cement (CAS 65997-15-1)

Irritant effect on skin                      Irritating to skin and mucous membranes

Irritant effect on eyes                      Irritating to eyes.

**Material Safety Data Sheet as per regulation (EC)**

1907/2006

Commercial Product Name: FIS P 300 T

Revision date: 30.07.2013

Version: 3.2/en

Print date: 30.07.2013

**11.2 Additional information**

Other information (chapter 11.) The product itself has not been tested.

**SECTION 12: Ecological information**
**12.1 Toxicity**

Toxicity to fish [mg/l]

Value	Test criterion	Test species	Duration of dosage	Measuring method	Remarks
> 500	LC50	Leuciscus idus (Golden orfe)	96 h		ethanediol (CAS 107-21-1)
493	LC50	Leuciscus idus (Golden orfe)	48 h	DIN 38412	2-hydroxypropyl methacrylate (CAS 27813-02-1)

Toxicity to daphnia [mg/l]

Value	Test criterion	Test species	Exposure duration	Measuring method	Remarks
> 100	EC50	Daphnia magna (Water flea)	48 h	OECD Test Guideline 202	ethanediol (CAS 107-21-1)
380	EC50	Daphnia magna (Water flea)	48 h	OECD Test Guideline 202	2-hydroxypropyl methacrylate (CAS 27813-02-1)

Toxicity to algae [mg/l]

Value	Test criterion	Test species	Exposure duration	Measuring method	Remarks
> 6500	EC50	Selenastrum capricornutum	96 h		ethanediol (CAS 107-21-1)
345	EC50	Selenastrum capricornutum	72 h	OECD Test Guideline 201	2-Hydroxypropylmethacrylat (CAS 27813-02-1)

NOEC (Daphnie) [mg/l]

Value	Duration of dosage	Test species	Measuring method	Test criterion	Remarks
24,1	21 d	Daphnia magna (Big water flea).	OECD TG 202	NOEC	2-hydroxypropyl methacrylate (CAS 27813-02-1)

**12.2 Persistence and degradability**

Elimination and distribution mechanisms There is no data available for this product.

Elimination in purification plant There is no data available for this product.

**12.3 Bioaccumulative potential**

Bioaccumulation There is no data available for this product.

Bioconcentration factor (BCF) There is no data available for this product.

**12.4 Mobility in soil**

Distribution in the environment There is no data available for this product.

**Material Safety Data Sheet as per regulation (EC)**



1907/2006

Commercial Product Name: FIS P 300 T

Revision date: 30.07.2013

Version: 3.2/en

Print date: 30.07.2013

**Mobility**

Mobility: There is no data available for this product.

**12.5 Results of PBT and vPvB assessment**

Results of PBT characteristics determination This preparation contains no substance considered to be very persistent nor very bioaccumulating (vPvB).

**12.6 Other adverse effects**

Further information on ecology The product itself has not been tested.

**SECTION 13: Disposal considerations**

**13.1 Waste treatment methods**

Disposal considerations The product should not be allowed to enter drains, water courses or the soil.  
Dispose of waste according to applicable legislation.  
Empty remaining contents.

Waste Code According to the European Waste Catalogue, Waste Codes are not product specific, but application specific.  
The following Waste Codes are only suggestions:  
Product (Mortar and Curing agent)  
200127 - paint, inks, adhesives and resins containing dangerous substances  
080409 - waste adhesives and sealants containing organic solvents or other dangerous substances  
cured material and completely squeezed cartridges  
200000 - MUNICIPAL WASTES (HOUSEHOLD WASTE AND SIMILAR COMMERCIAL, INDUSTRIAL AND INSTITUTIONAL WASTES) INCLUDING SEPARATELY COLLECTED FRACTIONS

**SECTION 14: Transport information**

	Land transport ADR/RID	Marine transport IMDG	Air transport ICAO/IATA
UN-No	Not applicable.	Not applicable.	Not applicable.
Class	Not applicable.	Not applicable.	Not applicable.
Packaging group	Not applicable.	Not applicable.	Not applicable.
Description of the goods	No dangerous good according to ADR	No dangerous good according to IMDG	No dangerous good according to IATA
Proper shipping name		Non dangerous good	Non dangerous good
Danger releasing substance	Not applicable.	Not applicable.	Not applicable.
Environmental hazards	Not applicable.	Not applicable.	Not applicable.

**14.6 Special precautions for user**

Precautions not required under normal use



**Material Safety Data Sheet as per regulation (EC)**



1907/2006

Commercial Product Name: FIS P 300 T

Revision date: 30.07.2013

Version: 3.2/en

Print date: 30.07.2013

**14.7 Transport in bulk according to Annex II of MARPOL73/78 and the IBC Code**

Transport in bulk according to Annex II of MARPOL73/78 and the IBC Code      not applicable

**14.8 Additional information**

Other information (chapter 14.)      Not dangerous goods in the meaning of ADR/RID, ADNR, IMDG-Code, ICAO/IATA-DGR

**SECTION 15: Regulatory information**

**15.1 Safety, health and environmental regulations/legislation specific for the substance or mixture**

Additional regulations      Not applicable.

**15.2 Chemical safety assessment**

Safety assessment      Not relevant. Chemical safety assessments for substances in this mixture were not carried out.

**SECTION 16: Other information**

Relevant R-phrases	R10: Flammable. R22: Harmful if swallowed. R36: Irritating to eyes. R37/38: Irritating to respiratory system and skin. R41: Risk of serious damage to eyes. R43: May cause sensitisation by skin contact.
Relevant H-phrases	H302: Harmful if swallowed. H373: May cause damage to organs through prolonged or repeated exposure . H226: Flammable liquid and vapour. H241: Heating may cause a fire or explosion. H315: Causes skin irritation. H317: May cause an allergic skin reaction. H318: Causes serious eye damage. H319: Causes serious eye irritation. H335: May cause respiratory irritation.
Wording of the hazard classes	Skin Irrit.: Skin irritation Eye Dam.: Serious eye damage Skin Sens.: Skin sensitization STOT SE: Specific target organ toxicity - single exposure Eye Irrit.: Serious eye irritation Acute Tox.: Acute toxicity STOT RE: Specific target organ toxicity - repeated exposure Org. Perox.: Organic peroxide Flam. Liq.: Flammable liquid

**Material Safety Data Sheet as per regulation (EC)**



1907/2006

Commercial Product Name: FIS P 300 T

Revision date: 30.07.2013

Version: 3.2/en

Print date: 30.07.2013

Modifications since last version

SECTION 2 Classification according to Regulation (EC) No. 1272/2008 [CLP]

Classification for mixtures and used evaluation method according to regulation (EC) 1207/2008 [CLP]

Classification	Evaluation
Skin Irrit. 2; H315	Calculated
Eye Dam. 1; H318	Calculated
Skin Sens. 1; H317	Calculated

Recommended restrictions

None under normal processing. Observe technical data sheet.

This information is provided in accordance with the current status of our knowledge and experience. The Safety Data Sheet describes products with a view to relevant safety requirements. This information does not constitute a warranty of properties, features or qualities.

## 12. Documentation changelog

### **From v7.1 to v7.2:**

- Added Lorient license type recommendation
- Changed Lorient batch import format due to the new Lorient Network Server 5.0

### **From v7.0 to v7.1:**

- Added safety guide for Smart Parking Chemical Fixing Cartridge
- Errata correction